



HARDWARE FOR WINDOWS AND DOORS

http://www.masteritaly.com

SCHEDA TECNICA DI MONTAGGIO

Lightflex

Manovra a libro / Fisarmonica (apertura esterna / interna)
Folding doors system (outside / inside opening)

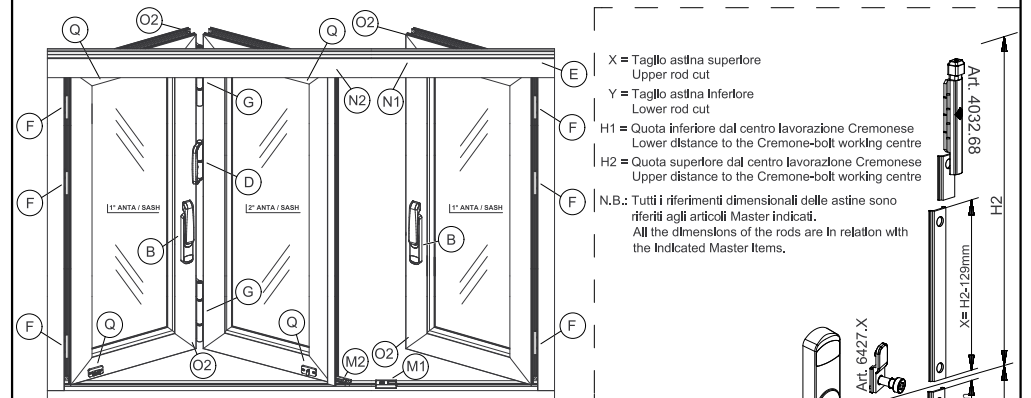
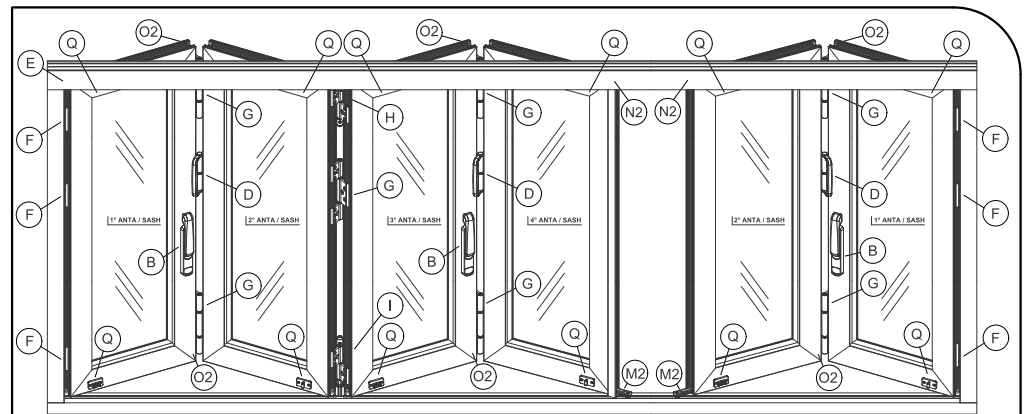

X = Taglio asina superiore
Upper rod cut
Y = Taglio asina inferiore
Lower rod cut
H1 = Quota inferiore dal centro lavorazione Cremonese
Lower distance to the Cremonese-bolt working centre
H2 = Quota superiore dal centro lavorazione Cremonese
Upper distance to the Cremonese-bolt working centre
N.B.: Tutti i riferimenti dimensionali delle asine sono riferiti agli articoli Master indicati.
All the dimensions of the rods are in relation with the indicated Master items.

Per garantire un corretto taglio delle ante, consigliamo di tagliare l'ultima successivamente al montaggio delle altre.
In order to guarantee the correct cut of the sashes, we suggest to cut the last sash after the assembling of the others.

- Dimensioni e portata massima Anta singola:
- Dimensions and Maximum load capacity / Single sash:

Tipologia / Type	Articolo / Article	H max	L min	L max	Portata max
	Art. 9147.4 Cerniera 2 ali Art. 9147.46 Cerniera 3 ali	1500 mm	-	700 mm	50 Kg per anta
	Art. 9147.4 Cerniera 2 ali Art. 9147.46 Cerniera 3 ali	2500 mm	-	700 mm	60 Kg per anta
	Art. 9147.4 Cerniera 2 ali Art. 9147.46 Cerniera 3 ali	1500 mm	350 mm	700 mm	50 Kg per anta
	Art. 9147.4 Cerniera 2 ali Art. 9147.46 Cerniera 3 ali	2500 mm	350 mm	700 mm	60 Kg per anta

L'esperto Consiglia:
Per eventuali chiarimenti chiedere info al nostro Uff. Tecnico tel. 080.4959823

MASTER S.r.l. - I362H - 04/10/2024 La Master Srl non risponde in nessun modo di possibili inesattezze imputabili ad errori di stampa o di trascrizione dati nel presente foglio.

TAB. 7

A6027.10
IT - Cremonese ribassata (apertura 90°) pinne reversibili
EN - Cremonese bolt (opening 90°) reversible racks
FR - Crémone baissée (ouverture 90°) fourches réversibles
ES - Cremona plana (apertura 90°) palas reversibles

A6027.15
IT - Cremonese ribassata (apertura 90°) pinne da 42mm
EN - Lowered cremonese bolt (opening 90°) racks 42mm
FR - Crémone baissée (ouverture 90°) fourches de 42mm
ES - Cremona plana (apertura 90°) palas 42mm

A6027.17
IT - Cremonese ribassata (apertura 90°) pinne da 37mm
EN - Lowered cremonese bolt (opening 90°) racks 37mm
FR - Crémone baissée (ouverture 90°) fourches de 37mm
ES - Cremona plana (apertura 90°) palas 37mm

TAB.11

A93635
IT - Corpo carrello per scorrevole
EN - Roller body
FR - Corps galet pour coulissant
ES - Cuerpo rueda

A83635.3
IT - Tassello guida inferiore per scorrevole
EN - Plug for lower guide for sliding
FR - Tasseau guide inférieure pour coulissant
ES - Tapón para guía inferior para corredera

A83635.1
IT - Ferma anta per scorrevole / Incontro di chiusura
EN - Sash stopper for Sliding Unit / Closing Keeper
FR - Clip parcloze pour coulissants / Gache de fermeture
ES - Bloqueo hoja para correderas

A83635.2
IT - Tassello incontro guida superiore per scorrevole
EN - Plug for lower guide for sliding
FR - Tasseau gache guide supérieure pour coulissant
ES - Tapón para guía inferior para corredera

TAB. 8

A6028.x
IT - Cremonese Comfort Plus con pinne guida per anta principale
EN - Comfort Plus Cremonese Bolt with guide racks for main sash
FR - Crémone Comfort plus avec fourches guide pour vantail principal
ES - Cremona comfort plus con palas guías para hoja principal

A6028.x
IT - Cremonese Comfort Plus con chiave e pinne guida per anta principale
EN - Comfort Plus Cremonese Bolt with key and guide racks for main sash
FR - Crémone Comfort Plus avec clé et fourches guide pour vantail principal
ES - Cremona comfort plus con llave y palas guías para hoja principal

TAB.12

A93638.7
IT - Blocca anta con Maniglia A3060
EN - Sash stopper with handle A3060
FR - Butée de coulissant avec Poignée A3060
ES - Bloqueo hoja con manilla A3060

A93638.6
IT - Blocca anta con Maniglia A6027
EN - Sash stopper with handle A6027
FR - Butée de coulissant avec Poignée A6027
ES - Bloqueo hoja con manilla A6027

A93638.5
IT - Paracolpi con Maniglia A3060
EN - Door bumper with handle A3060
FR - Bloc-vantail avec Poignée A3060
ES - Amortiguador con manilla A3060

A93638.4
IT - Paracolpi con Maniglia A6027
EN - Door bumper with handle A6027
FR - Bloc-vantail avec Poignée A6027
ES - Amortiguador con manilla A6027

TAB. 9

A6427.1
IT - Blocchetti di collegamento Cremonese (entrata ≤18mm)
EN - Junction blocks for cremonese bolt (backset ≤18mm)
FR - Blocs de jonction Crémone (entrée ≤18mm)
ES - Bloqueos de unión para Cremona (entrada ≤18mm)

A6427.2
IT - Blocchetti di collegamento Cremonese (entrata ≤33mm)
EN - Junction blocks for cremonese bolt (backset ≤33mm)
FR - Blocs de jonction Crémone (entrée ≤33mm)
ES - Bloqueos de unión para Cremona (entrada ≤33mm)

A93638.1
IT - Riscontri di chiusura Cremonese (entrata ≤18mm)
EN - Counterplate for cremonese bolt (backset ≤18mm)
FR - Gâches de fermeture Crémone (entrée ≤18mm)
ES - Cerraderos para Cremona (entrada ≤18mm)

TAB.13

A2337.2
IT - Tappi copri barra scorrevole
EN - Covering Plugs for Sliding Bar
FR - Bouchons couvre-barre coulissante
ES - Tapas para barra corredera

A2337.1
IT - Tappi maggiorati copri barra scorrevole
EN - Bigger Covering Plugs for Sliding Bar
FR - Bouchons majorés couvre-barre coulissante
ES - Tapas grandes para barra corredera

A2337.3
IT - Tappi Copri Barra scorrevole motorizzato
EN - Covering Plugs for Motorized Sliding Bar
FR - Bouchons couvre-barre coulissante motorisée
ES - Tapas para barra corredera motorizada

TAB.10

A93638.2
IT - Incontro Catenaccio (solo per telaio da 15mm)
EN - Latch keeper (only for 15mm frame)
FR - Gâche (seulement pour chassis de 15mm)
ES - Encuentro pasador (solo para marco de 15mm)

A93638.9
IT - Incontro Catenaccio (solo per telaio da 12mm)
EN - Latch keeper (only for 12mm frame)
FR - Gâche (seulement pour chassis de 12mm)
ES - Encuentro pasador (solo para marco de 12mm)

A4032.68
IT - Terminale catenaccio Sirio
EN - Rod-end for latch Sirio
FR - Embout de tringle Sirio
ES - Terminal pasador Sirio

TAB.14

A2337
IT - Tappo coprilavorazione per telaio superiore
EN - Cover plug for upper frame
FR - Bouchon cache-usinage
ES - Tapón mecanizado para marco superior

TAB. 6

A93638.8
IT - Maniglia di traino per apertura esterna
EN - Pulling Handle for External Opening
FR - Poignée de traitement pour ouverture extérieure
ES - Manilla tiradora para apertura externa

A83635.6
IT - Blochetto inferiore per anta per manovra a libro
EN - Lower block for even sash for folding opening cavity
FR - Bloc inférieure pour vantail canal 15mm
ES - Bloqueo inferior para hoja per en la apertura plegable canal 15mm

A83635.5
IT - Blochetto inferiore per anta per manovra a libro
EN - Lower block for even sash for folding opening cavity
FR - Bloc inférieure pour vantail canal 12mm
ES - Bloqueo inferior para hoja per en la apertura plegable canal 12mm

A93635.4
IT - Blochetto superiore per anta per manovra a libro
EN - Upper block for even sash for folding opening
FR - Bloc supérieure pour vantail
ES - Bloqueo superior para hoja per en la apertura plegable

TAB. 1

A0343
IT - Squadretta in Alluminio estruso per profilo anta
EN - Extruded corner for sash profile
FR - Equerre en Aluminium extrudé pour profilé vantail
ES - Escuadra de fundición para perfil hoja

A0262
IT - Squadretta in Alluminio estruso per profilo anta
EN - Extruded corner for sash profile
FR - Equerre en Aluminium extrudé pour profilé vantail
ES - Escuadra en aluminio extruido

TAB. 4

A9148.4
IT - Cerniera maggiorata Rapid 2 ali
EN - Rapid reinforced hinge 2 wings
FR - Paumelle majorée Rapid 2 ailes
ES - Rapido - bisagra reforzada de 2 alas

A9148.46
IT - Cerniera maggiorata Rapid 3 ali
EN - Rapid reinforced hinge 3 wings
FR - Paumelle majorée Rapid 3 ailes
ES - Rapido - bisagra reforzada de 3 alas

A93630.68
IT - Cerniera Rapid Inferiore per cava 15mm
EN - Rapid lower hinge for cavity 15mm
FR - Paumelle Rapid inférieure pour canal 15mm
ES - Rapido bisagra inferior para canal 15mm

A93630.6A
IT - Cerniera Rapid Inferiore per cava 12mm
EN - Rapid lower hinge for cavity 12mm
FR - Paumelle Rapid inférieure pour canal 12mm
ES - Rapido bisagra inferior para canal 12mm

A93630.5A
IT - Cerniera Rapid superiore per manovra a libro
EN - Rapid upper hinge for folding opening
FR - Paumelle Rapid supérieure pour manœuvre à acordon
ES - Rapido bisagra superior para plegable

TAB. 3

A93630.5A
IT - Cerniera Rapid 3 ali
EN - Rapid Hinge 3 wings
FR - Paumelle Rapid 3 ailes
ES - Rapido - bisagra de 3 alas

A9147.46
IT - Cerniera Rapid 2 ali
EN - Rapid hinge 2 wings
FR - Paumelle Rapid 2 ailes
ES - Rapido - bisagra de 2 alas

TAB. 2

A9147.4
IT - Cerniera Rapid / Rapid Hinge
EN - Rapid Hinge 3 all / Rapid Hinge 3 wings
FR - Paumelle Rapid 3 ailes
ES - Rapido - bisagra de 3 alas

TAB. 5

A93630.68
IT - Blochetto inferiore per manovra a libro (solo telaio cava 15mm) / Lower Hinge for Folding doors (only for frame cavity 15mm)
EN - Lower block for folding opening (only for frame cavity 15mm)
FR - Bloc inférieure pour vantail (seulement pour chassis de 15mm)
ES - Encuentro pasador inferior (solo para marco de 15mm)

A93630.6A
IT - Blochetto inferiore per manovra a libro (solo telaio cava 12mm) / Lower Hinge for Folding doors (only for frame cavity 12mm)
EN - Lower block for folding opening (only for frame cavity 12mm)
FR - Bloc inférieure pour vantail (seulement pour chassis de 12mm)
ES - Encuentro pasador inferior (solo para marco de 12mm)

A93630.5A
IT - Blochetto superiore per manovra a libro / Upper Hinge for Folding doors
EN - Upper block for folding opening
FR - Bloc supérieure pour vantail
ES - Encuentro pasador superior

A6027.X
IT - Cremonese ribassata / Reduced cremonese bolt
EN - Lowered cremonese bolt
FR - Crémone baissée
ES - Cremona plana

A6028.X
IT - Cremonese Comfort Plus con pinne guida per anta principale / Cremonese bolt with guide racks for main sash
EN - Comfort Plus Cremonese Bolt with guide racks for main sash
FR - Crémone Comfort plus avec fourches guide pour vantail principal
ES - Cremona comfort plus con palas guías para hoja principal

A6024.X
IT - Cremonese con chiave e pinne guida per anta principale / Cremonese bolt with key and guide racks for main sash
EN - Comfort Plus Cremonese Bolt with key and guide racks for main sash
FR - Crémone Comfort Plus avec clé et fourches guide pour vantail principal
ES - Cremona comfort plus con llave y palas guías para hoja principal

A6427.X
IT - Blocchetto di collegamento per Cremonese / Junction Block for Cremonese-bolt
EN - Junction blocks for cremonese bolt
FR - Blocs de jonction Crémone
ES - Bloqueos de unión para Cremona

A4032.68
IT - Terminale catenaccio Sirio / Rod end cover for Sirio latch
EN - Rod-end cover for Sirio latch
FR - Embout de tringle Sirio
ES - Terminal pasador Sirio

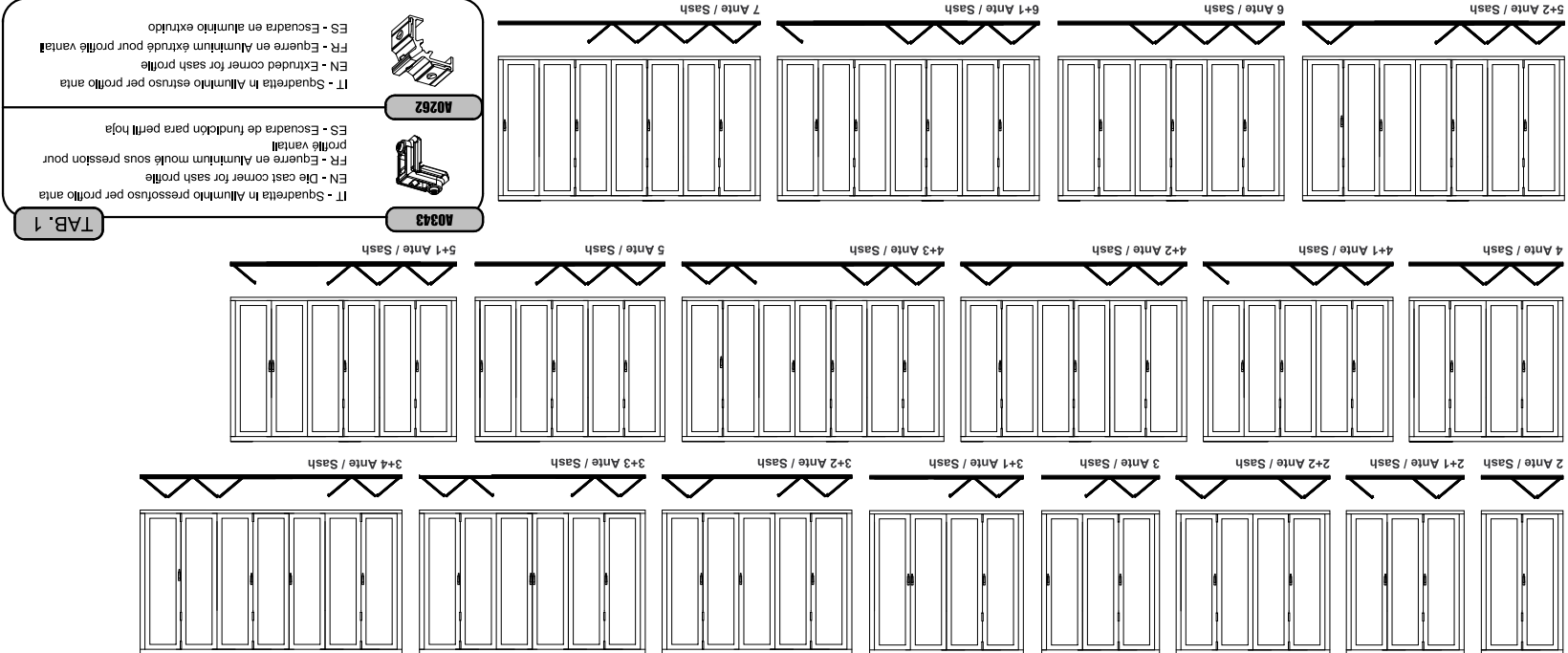

Articolo / Description	2	2+1	2+2	3	3+1	3+2	3+3	3+4	4	4+1	4+2	4+3	5	5+1	5+2	6	6+1	7
A9147.4	2	2+1	2+2	3	3+1	3+2	3+3	3+4	4	4+1	4+2	4+3	5	5+1	5+2	6	6+1	7
A9147.46	6	9	12	7	10	13	14	17	10	13	14	17	10	13	14	17	14	17
A93630.5A	-	-	-	-	-	-	-	-	-	-	-	-	-	-	-	-	-	-
A93630.6A	-	-	-	-	-	-	-	-	-	-	-	-	-	-	-	-	-	-
A93630.68	-	-	-	-	-	-	-	-	-	-	-	-	-	-	-	-	-	-
A6027.X	1	1	1	1	1	1	1	1	1	1	1	1	1	1	1	1	1	1
A6028.X	1	1	1	1	1	1	1	1	1	1	1	1	1	1	1	1	1	1
A6024.X	1	2	2	2	3	3	3	3	3	4	4	4	4	4	4	4	4	4
A6427.X	1	2	2	2	3	3	3	3	3	4	4	4	4	4	4	4	4	4
A4032.68	2	4	4	4	6	6	6	6	6	8	8	8	8	8	8	8	8	8
A93638.2	1	1	1	1	1	1	1	1	1	1	1	1	1	1	1	1	1	1
A93638.9	1	1	1	1	1	1	1	1	1	1	1	1	1	1	1	1	1	1
A93635.1	1	1	1	1	1	1	1	1	1	1	1	1	1	1	1	1	1	1
A93638.8	1	1	1	1	1	1	1	1	1	1	1	1	1	1	1	1	1	1
A93638.8	1	1	1	1	1	1	1	1	1	1	1	1	1	1	1	1	1	1
A93630.68	1	1	1	1	1	1	1	1	1	1	1	1	1	1	1	1	1	1
A93630.6A	1	1	1	1	1	1	1	1	1	1	1	1	1	1	1	1	1	1
A93635.4	1	1	1	1	1	1	1	1	1	1	1	1	1	1	1	1	1	1
A93630.5A	1	1	1	1	1	1	1	1	1	1	1	1	1	1	1	1	1	1
A93635.6	1	1	1	1	1	1	1	1	1	1	1	1	1	1	1	1	1	1
A6427.X	1	2	2	2	3	3	3	3	3	4	4	4	4	4	4	4	4	4
A0343	1	2	2	2	3	3	3	3	3	4	4	4	4	4	4	4	4	4
A0262	8	12	16	12	16	12	16	12	16	20	24	28	16	20	24	28	24	28
A2337	1	1	1	1	1	1	1	1	1	1	1	1	1	1	1	1	1	1

DISTINTA ACCESSORI IN RIFERIMENTO ALLE DIVERSE CONFIGURAZIONI
ACCESSORIES LIST ACCORDING TO THE DIFFERENT CONFIGURATIONS

- Configurazioni tipo apertura esterna / interna - Opening configuration external / internal:

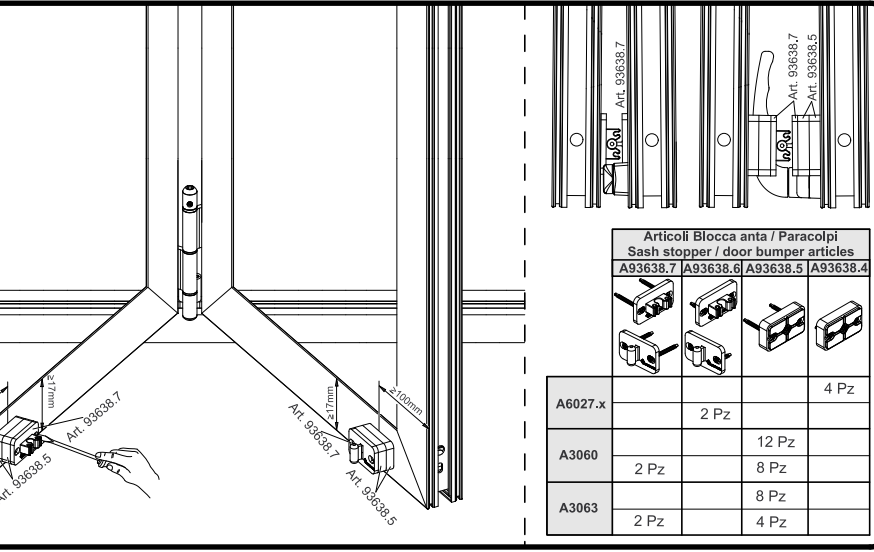
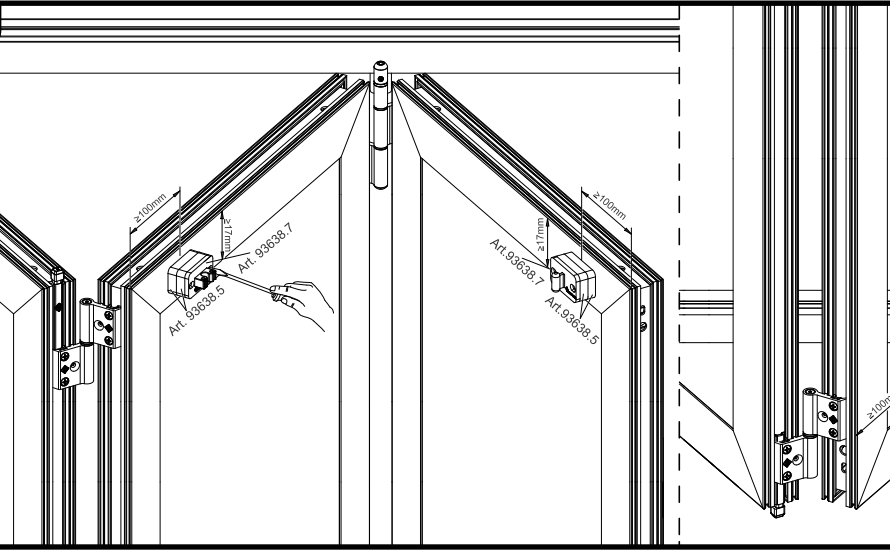
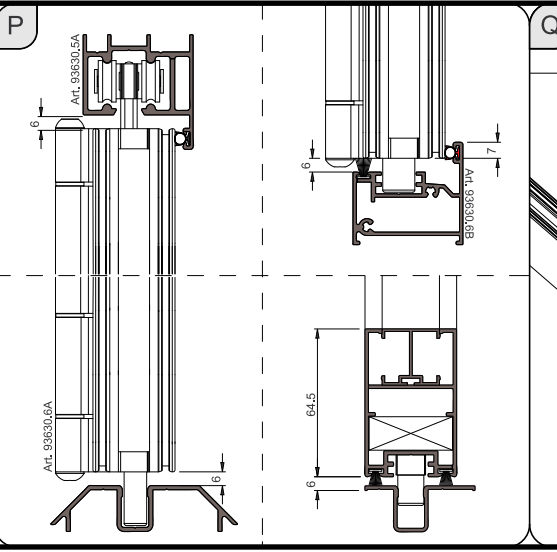
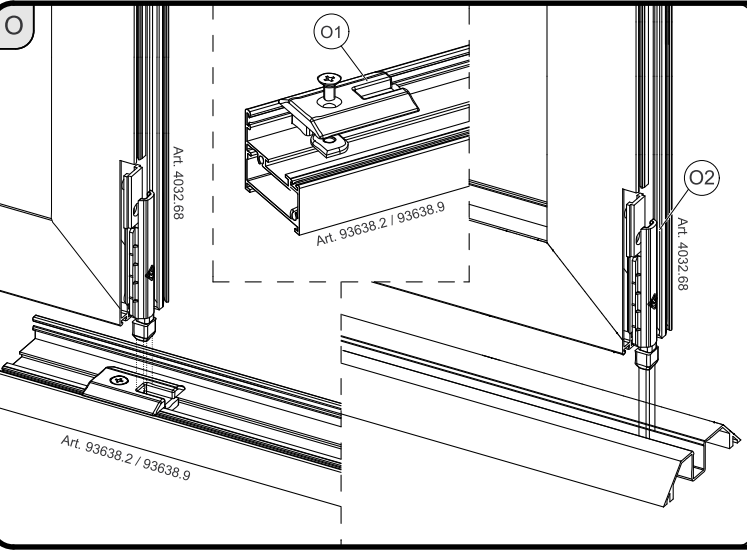
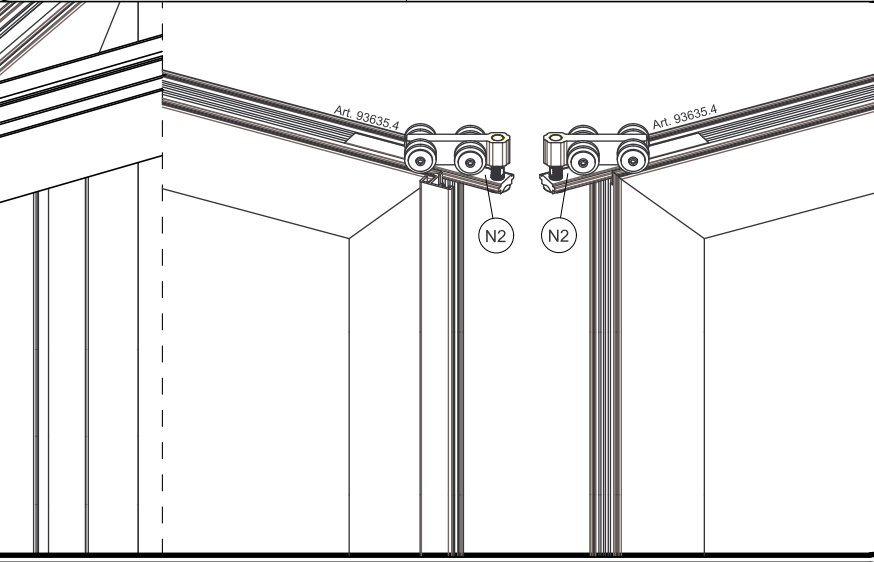
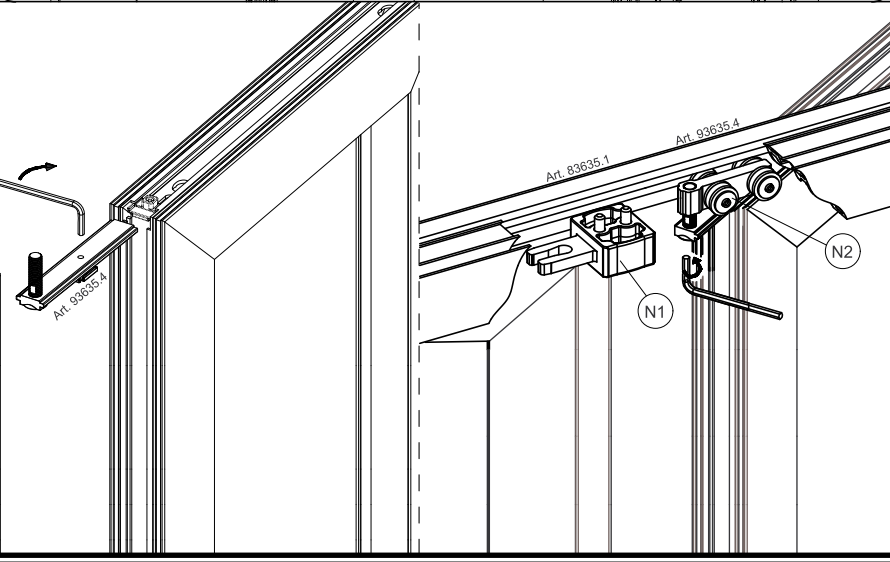
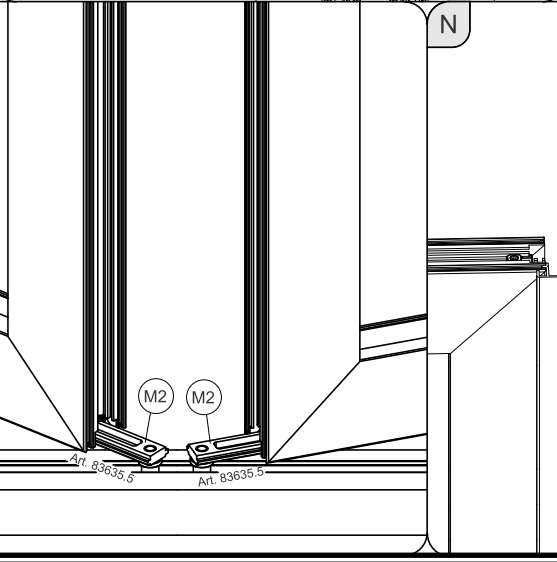
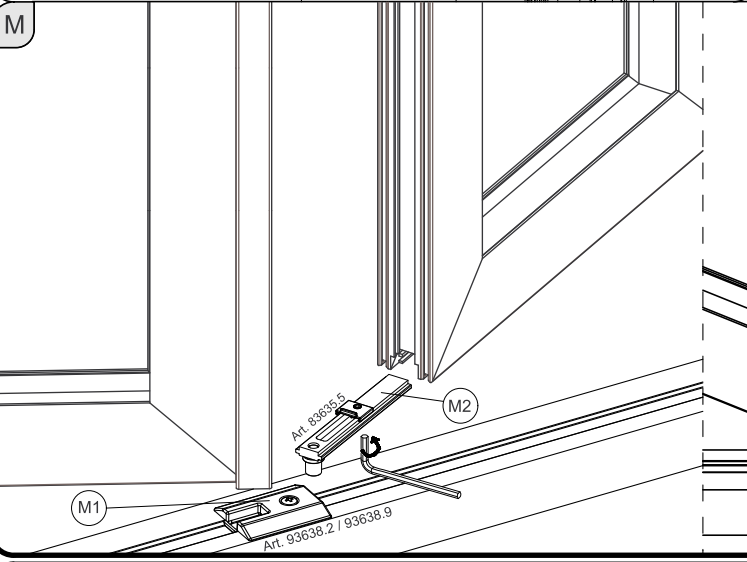
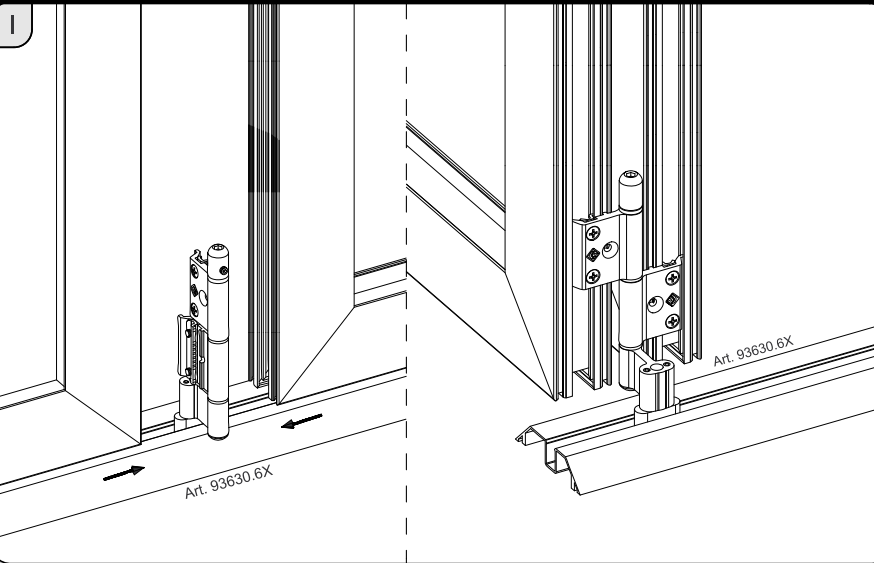
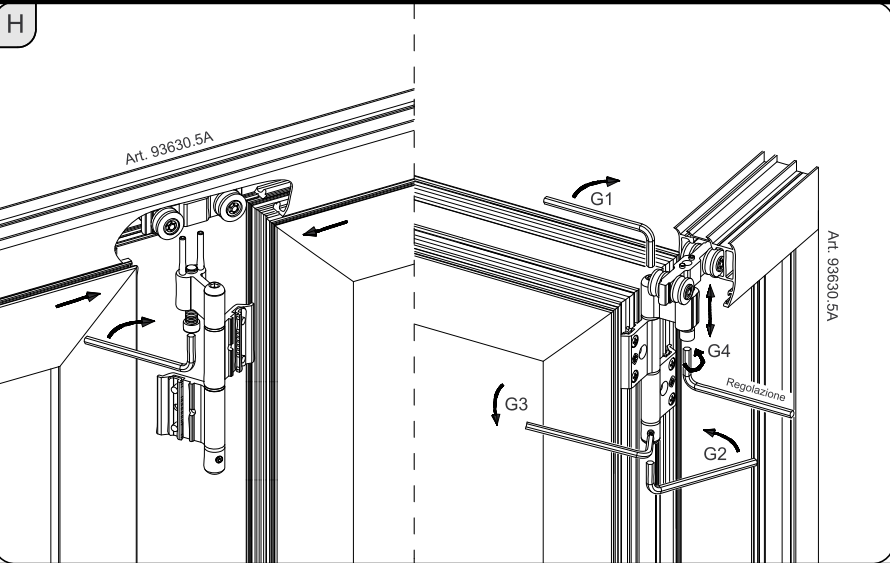
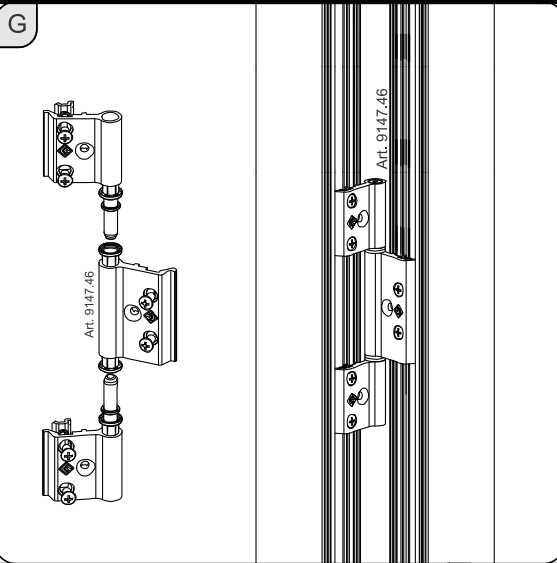
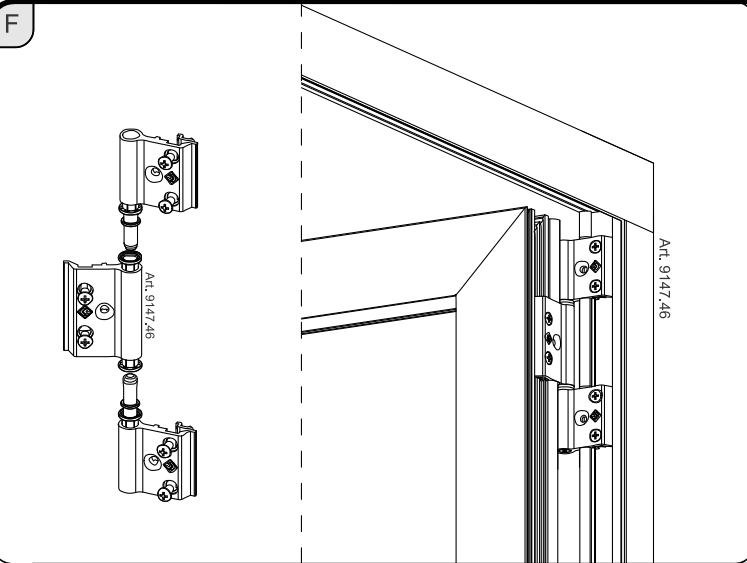
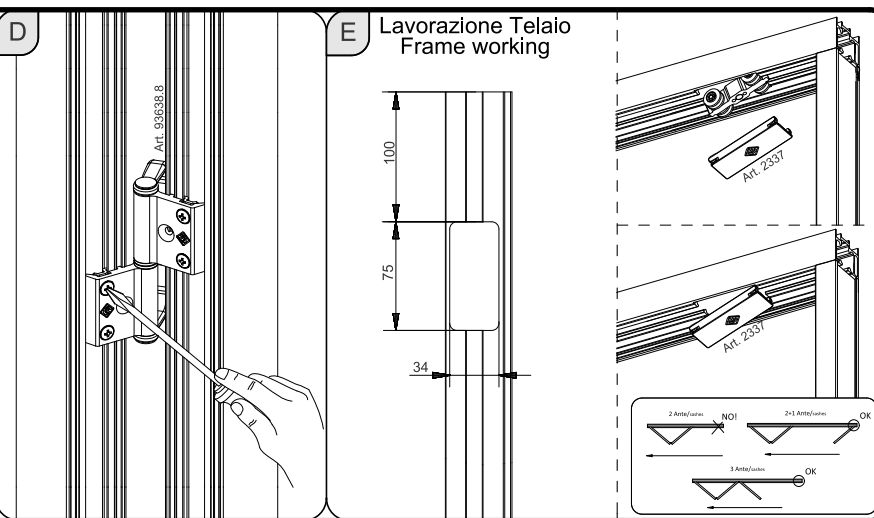
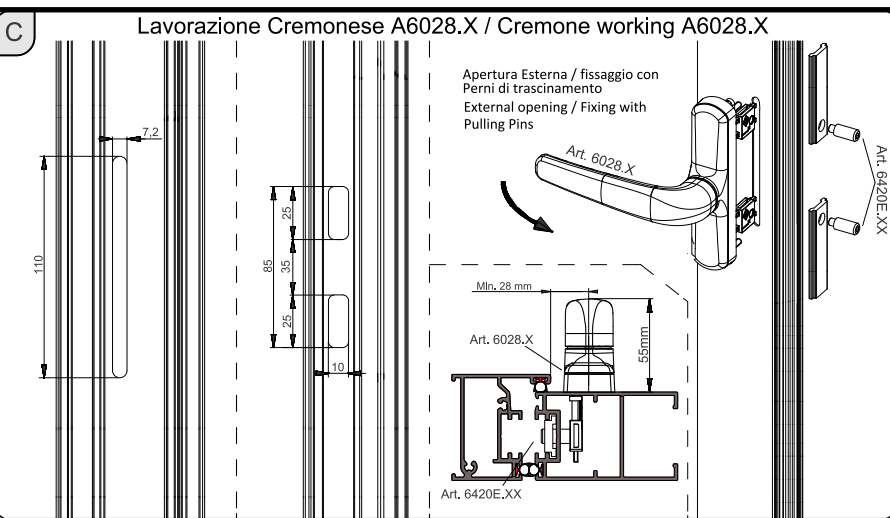
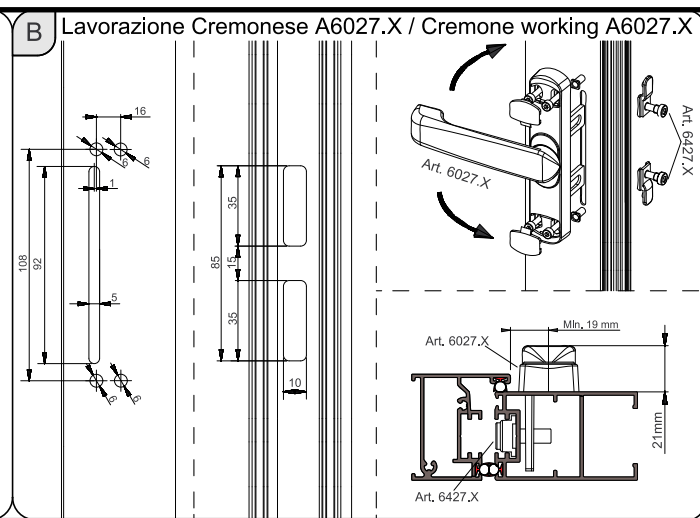
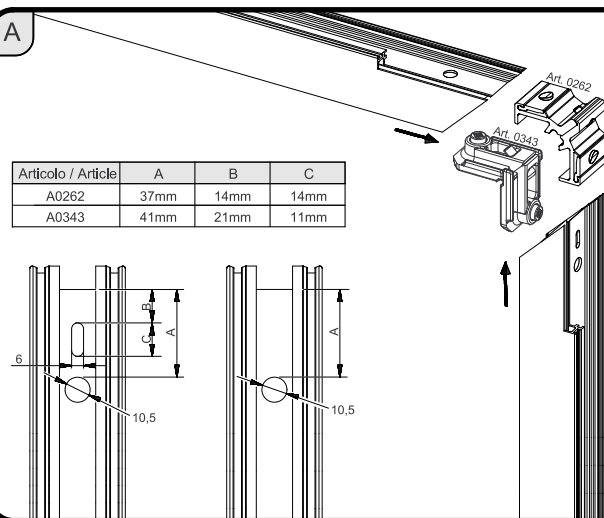

Articoli Blocca anta / Paracolpi
Sash stopper / door bumper articles

Articolo / Article	A	B	C	D
A6027.x		2 Pz		4 Pz
A3060		2 Pz	12 Pz	8 Pz
A3063		2 Pz	8 Pz	4 Pz