

Telaio - Frame

Lavorazioni / Machining

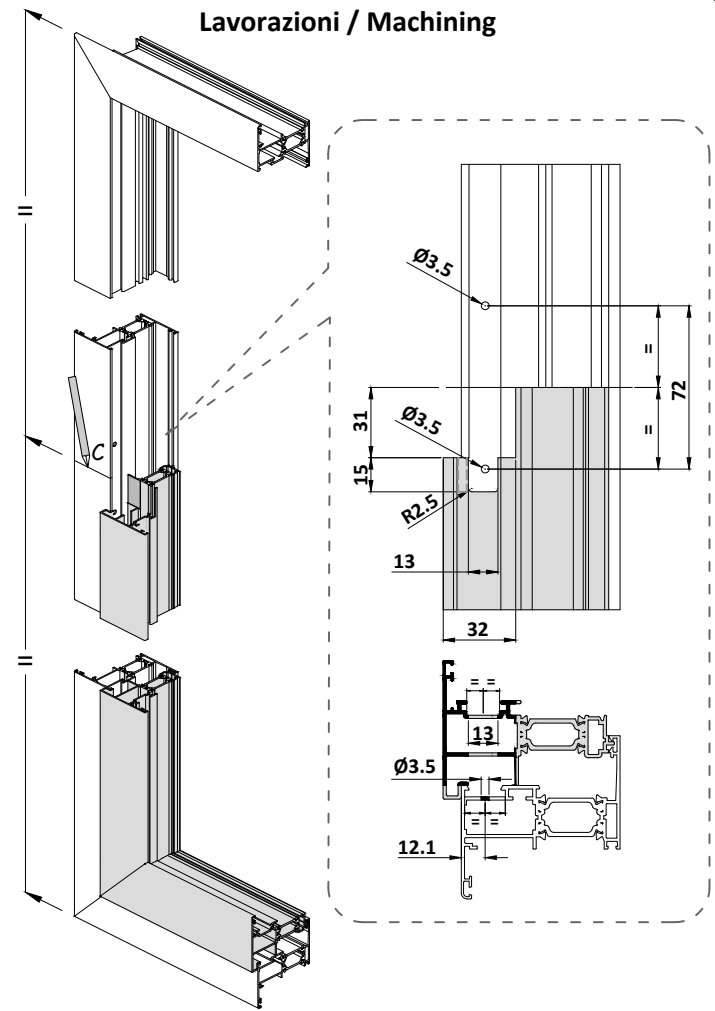

Montaggio / Assembly

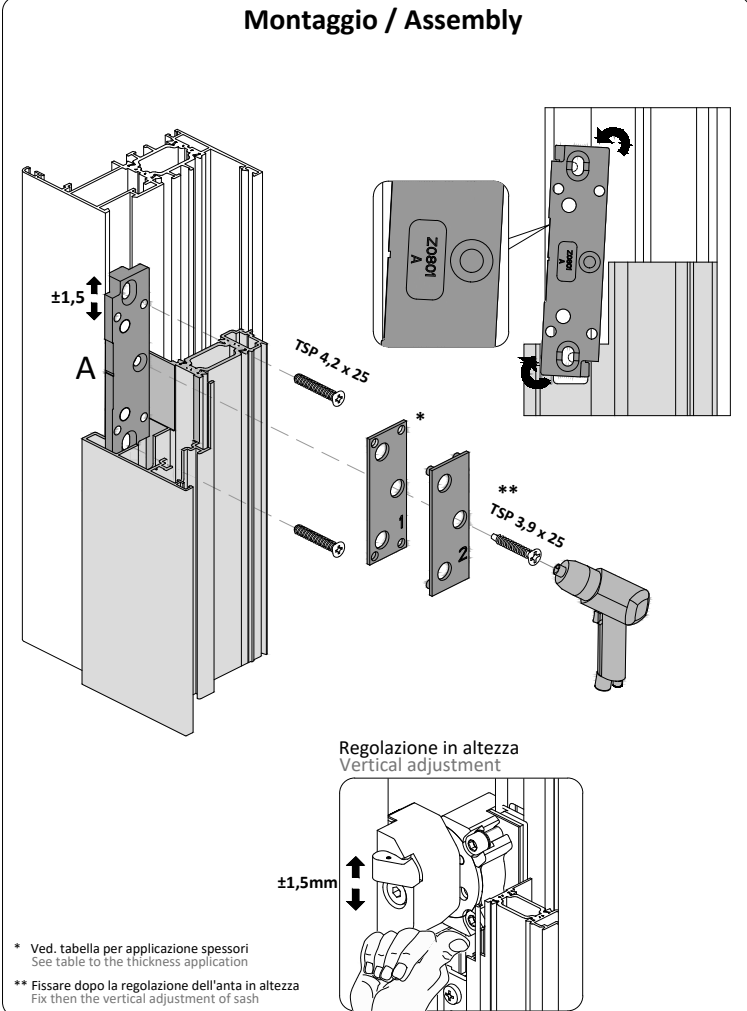

SCHEDA TECNICA DI MONTAGGIO

EasyPivot

<http://www.masteritaly.com>

CERNIERA A FRIZIONE PER FINESTRE BILICO ORIZZONTALI E VERTICALI
FRICTION HINGE FOR HORIZONTAL AND VERTICAL PIVOT WINDOWS
Per Camera Europea - For CE groove

Kit cerniere orizzontale con blocco
Hinges kit to horizontal with lock

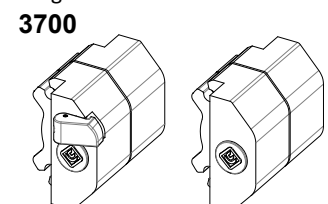

3700

Kit cerniere verticale senza blocco
Hinges kit to vertical without lock

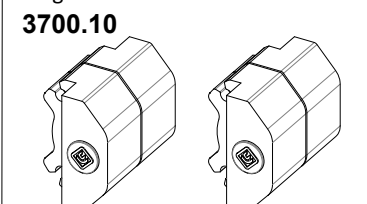

3700.10

Kit fissaggio cerniere
Hinges fixing kit

3710

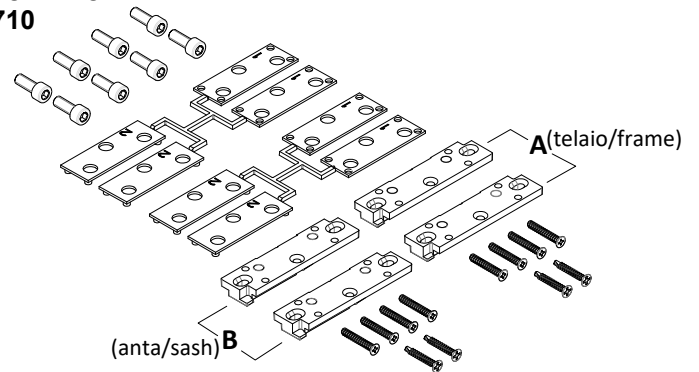

Kit chiusura perimetrale
Multi-point locking kit
3710.10 / 3710.11 / 3710.12

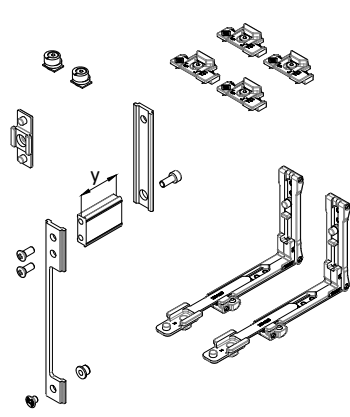

Kit chiusura supplementare
Additional multi-point locking kit
3710.20 / 3710.21 / 3710.22

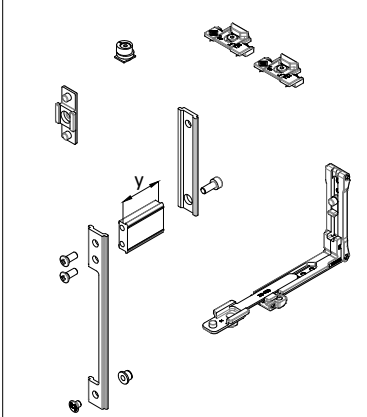

Riferimento nodo Camera Europea
Euro groove section riferiment

A	B	C	y	Kit chiusure
3.5	2	38 - 41	35.5	3710.11 - 3710.21
4	1.5 - 1.8 - 2	41.5 - 43	38.5	3710.10 - 3710.20
		43.5 - 46.5	41.5	3710.12 - 3710.22

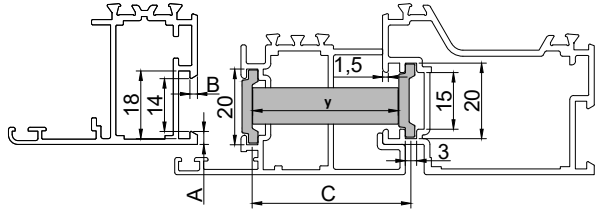

Norma di riferimento Europea UNI EN 13126-1:2006 / 13126-9:2006
Certified according to European Standard UNI EN 13126-1:2006 / 13126-9:2006

Hor.	-	5	120	0	1	4	-	9/1	1400x1400
Ver.	-	5	80	0	1	4	-	9/3	1400x1400
Categoria d'uso	Durabilità	Massa	Resistenza fuoco	Sicurezza di utilizzo	Resistenza alla corrosione	Resistenza effrazione	Applicazione	Dimensione di prova	
Category of use	Durability	Mass	Fire resistance	Safety in use	Corrosion resistance	Security	Applicable part	Test size	

Anta - Sash

Lavorazioni / Machining

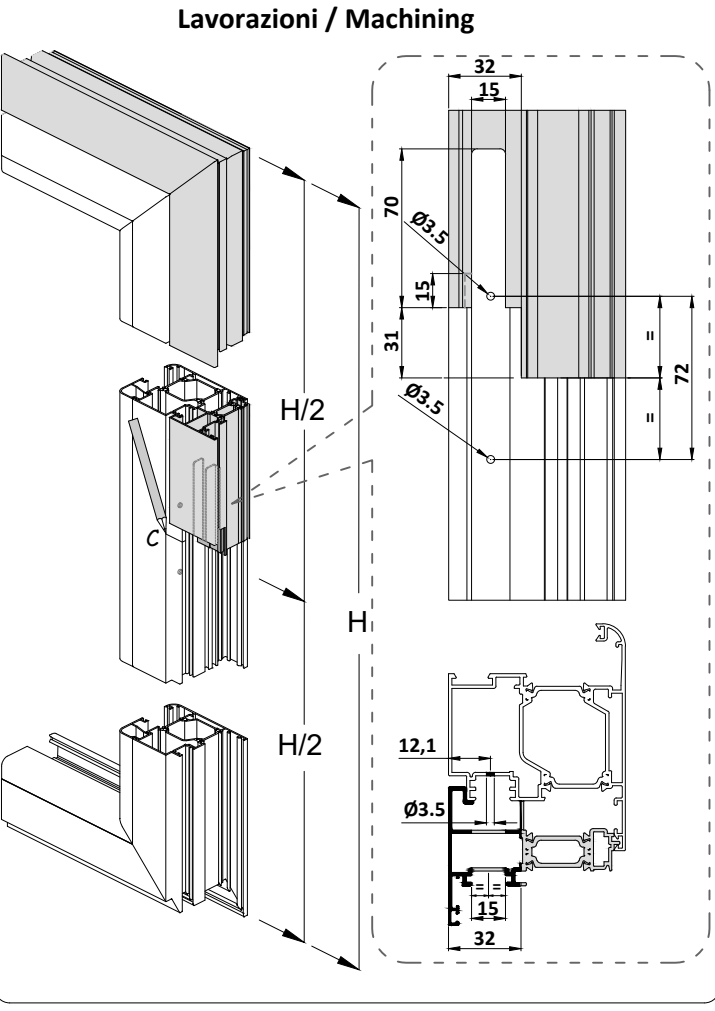

Montaggio / Assembly



Diagramma di carico - Application range

Horizontal



Vertical

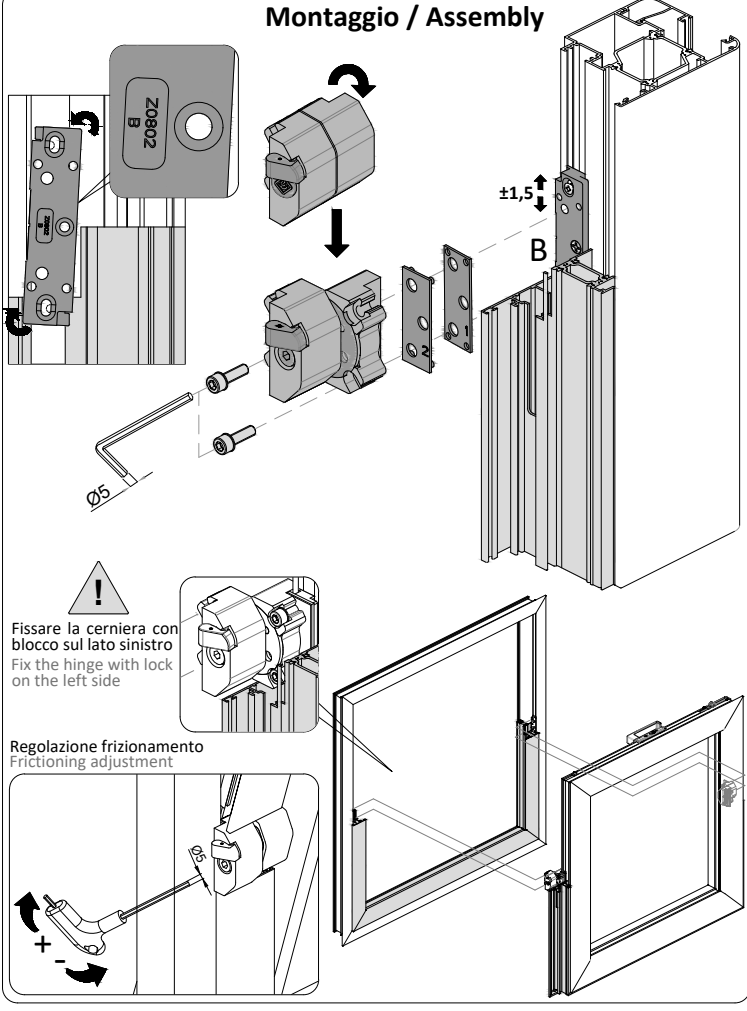
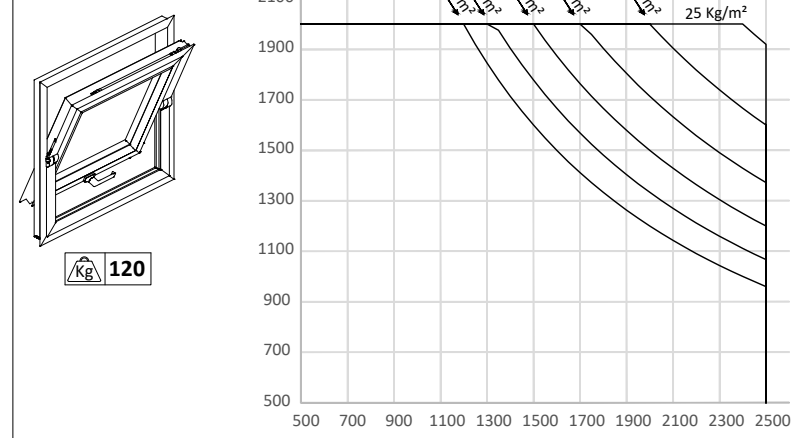
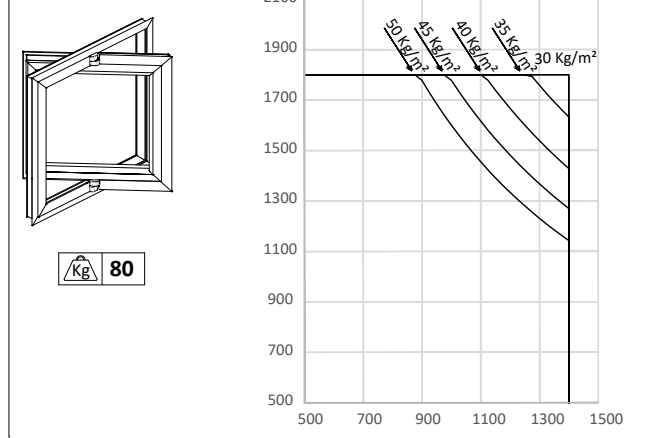

ESTRUSORE EXTRUDER	SERIE PROFILES MATCHING	SPESORE 1 THICKNESS 1	SPESORE 2 THICKNESS 2	KIT BASE BASIC KIT	KIT SUPPLEMENTARE SUPPLEMENTARY KIT
ALL.CO	EXPORT 50T - 45 - 45TT - 50 - 50TT - 51TT - 68TT			A3710.10	A3710.20
ALL.CO	ALL.COTEC 72	■	■	A3710.12	A3710.22
ALSISTEM	PLANET 45 - 50 - 62 - 72 PLUS			A3710.10	A3710.20
ALU-K	50 - 63 IW			A3710.10	A3710.20
COLMA	MA 68TT - 72HP - 77HTI			A3710.10	A3710.20
DFV	ECOWIN TH 62 - 72			A3710.10	A3710.20
HYDRO	DOMAL TB 65 - 75			A3710.12	A3710.22
HYDRO	DOMAL BREAK 52 - 63 - PA70 - PA70S			A3710.10	A3710.20
HYDRO	DOMAL BRIGHT PA 70S	■	■	A3710.12	A3710.22
ETA	ROAD 520TT - 600TT - START 410 - 560TT			A3710.10	A3710.20
IBLEA COLOR GROUP	VUERRE 53 TT			A3710.10	A3710.20
IBLEA COLOR GROUP	VUERRE 56TT	■	■	A3710.10	A3710.20
INDINVEST	GOLD 400 - 450 - 500 - DOGMA			A3710.10	A3710.20
INDINVEST	PLATHINA 69 - 75			A3710.12	A3710.22
PONZIO	WS 45 - 45TT - 55TT - 65TH			A3710.10	A3710.20
PROFILATI	EKU 40 - 45 - 53 - 62TT - 66TT HP - 78TT			A3710.10	A3710.20
TOMA	TIERRE 450TH - 550TH - 590TH - 600TH - 640TH			A3710.12	A3710.22
TWIN SYSTEMS	CX450 - 550 - 600 - 650 - 700 - 850			A3710.10	A3710.20

Horizontal Pivot Window

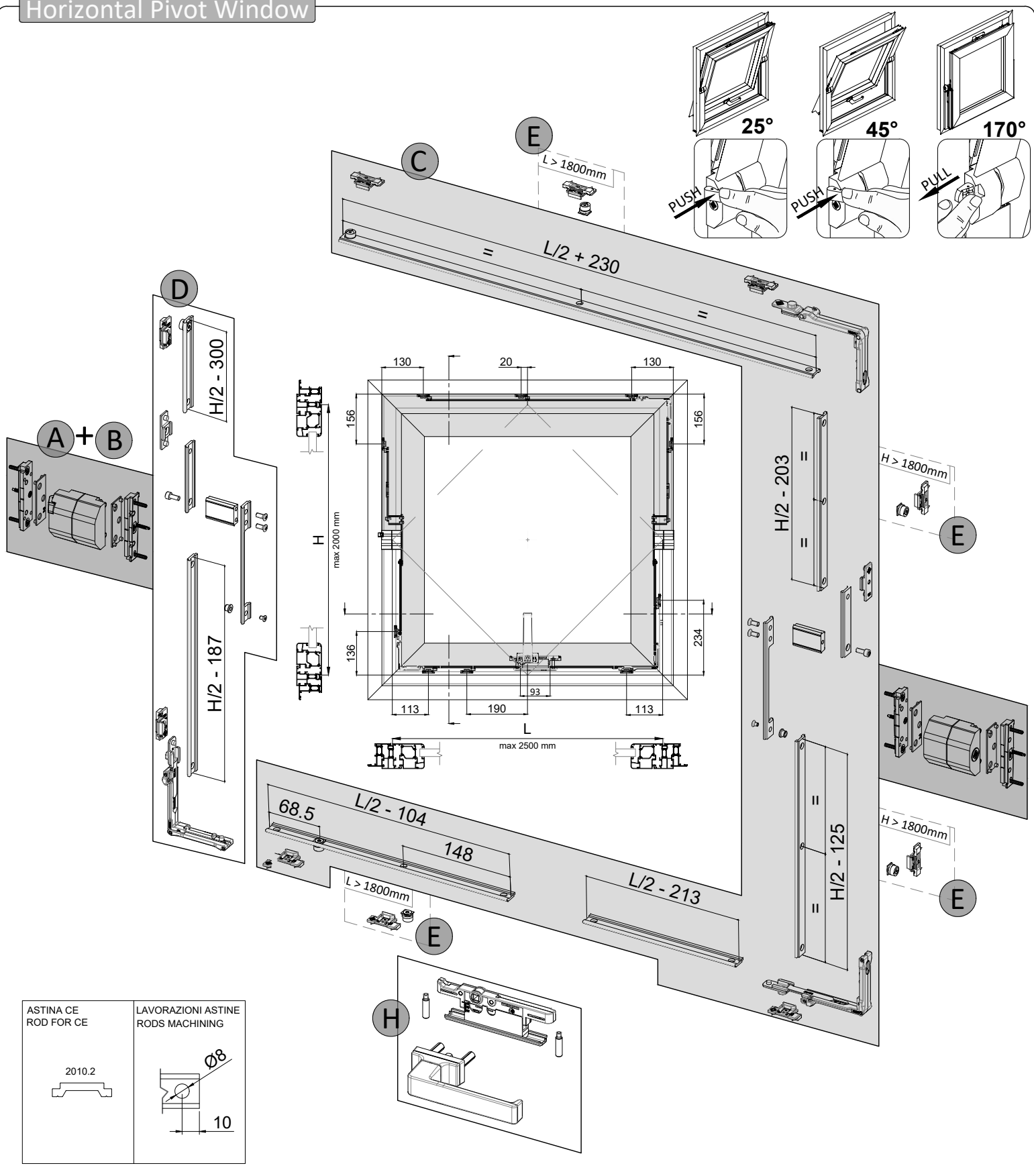

Vertical Pivot Window

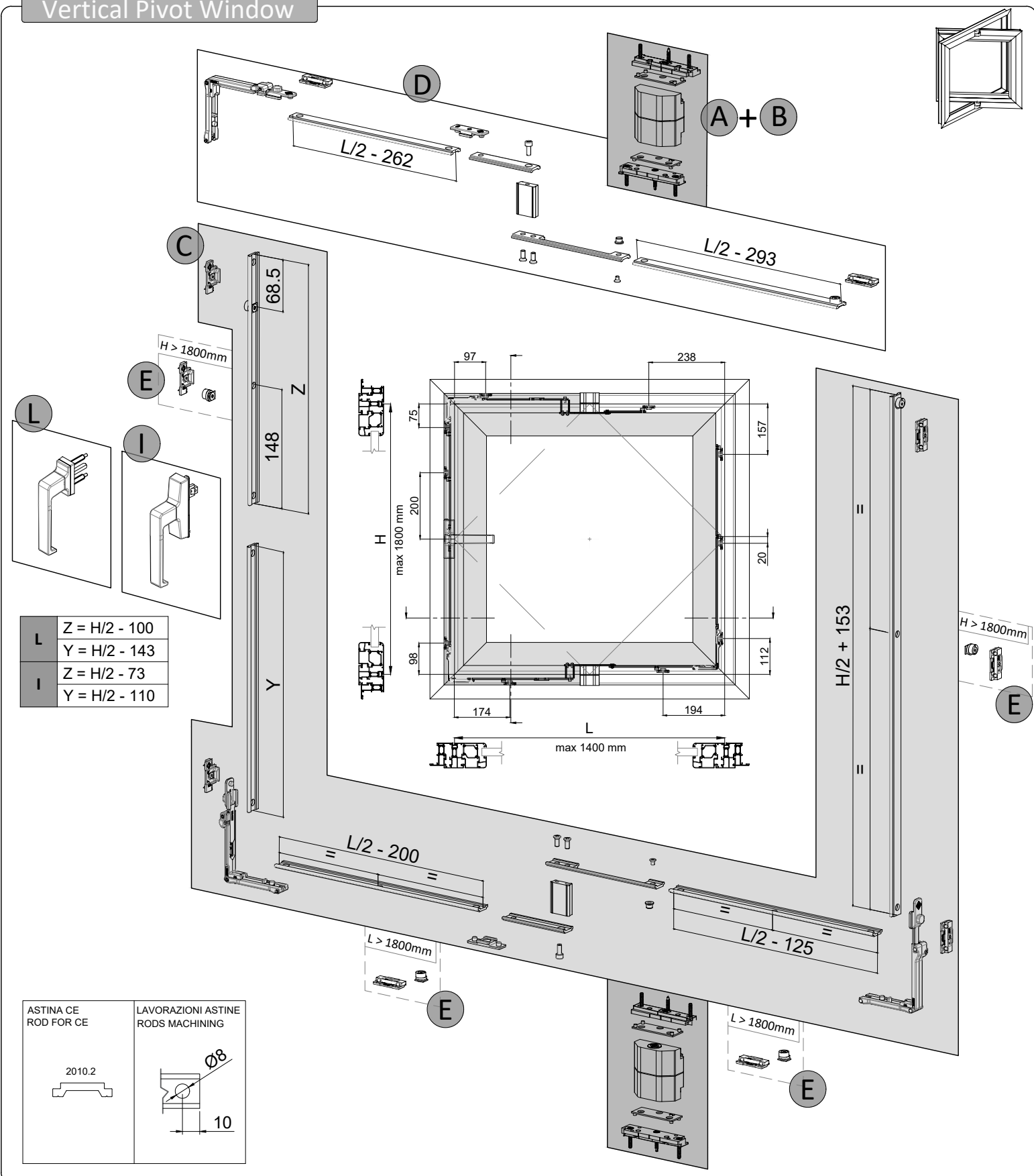

Distinta accessori / Accessories list

A	3700	1 cp	A	3700	1 cp
B	3710	1 pz	B	3710	1 pz
C	3710.10/11/12	1 pz	C	3710.10/11/12	1 pz
D	3710.20/21/22	1 pz	D	3710.20/21/22	1 pz
E	4207.11 + 4246	2 pz	E	4207.11 + 4246	4 pz

A	3700	1 cp	A	3700	1 cp
B	3710	1 pz	B	3710	1 pz
C	3710.10/11/12	1 pz	C	3710.10/11/12	1 pz
D	3710.20/21/22	1 pz	D	3710.20/21/22	1 pz

Maniglie Handles

3070	3072	3100 - 3100.1
-------------	-------------	----------------------

Altri accessori Other accessories

3626.2	6420E.XX
---------------	-----------------

E 4207.11 + 4246

Distinta accessori / Accessories list

A	3700.10	1 cp	A	3700.10	1 cp
B	3710	1 pz	B	3710	1 pz
C	3710.10/11/12	1 pz	C	3710.10/11/12	1 pz
D	3710.20/21/22	1 pz	D	3710.20/21/22	1 pz
E	4207.11 + 4246	2 pz	E	4207.11 + 4246	4 pz

A	3700.10	1 cp	A	3700.10	1 cp
B	3710	1 pz	B	3710	1 pz
C	3710.10/11/12	1 pz	C	3710.10/11/12	1 pz
D	3710.20/21/22	1 pz	D	3710.20/21/22	1 pz

Maniglie Handles

3070	3072	3100 - 3100.1	Altri accessori Other accessories
-------------	-------------	----------------------	--

3627 - 3627.2

E 4207.11 + 4246

L 6015 - 6011.10

I 6061

6018

6111.15

Telaio - Frame

Lavorazioni / Machining

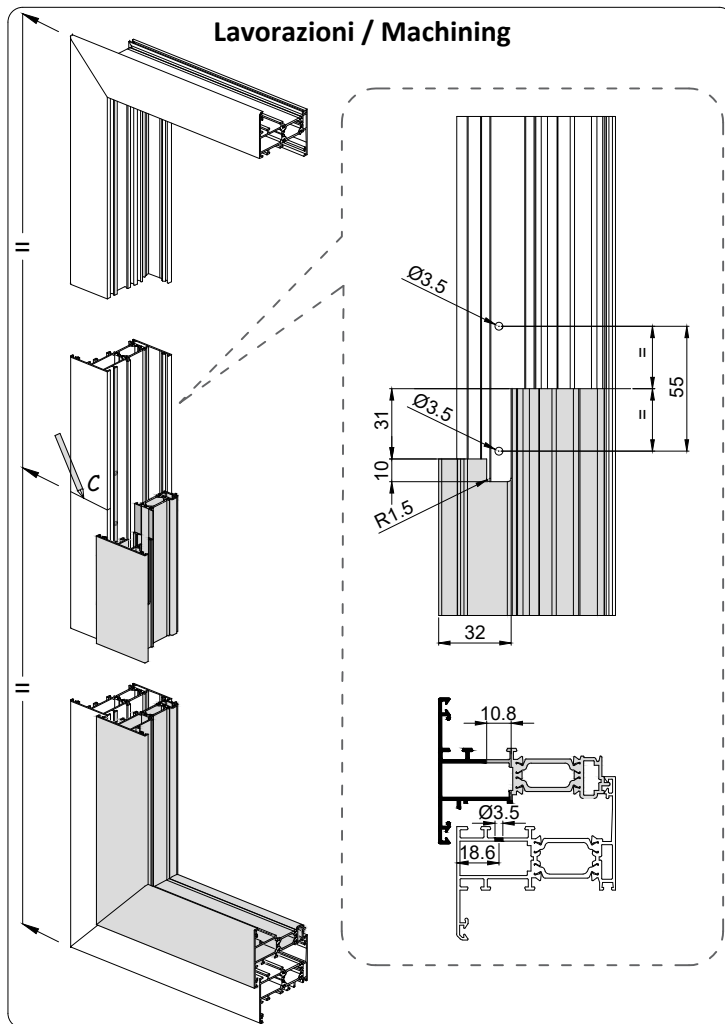

Montaggio / Assembly

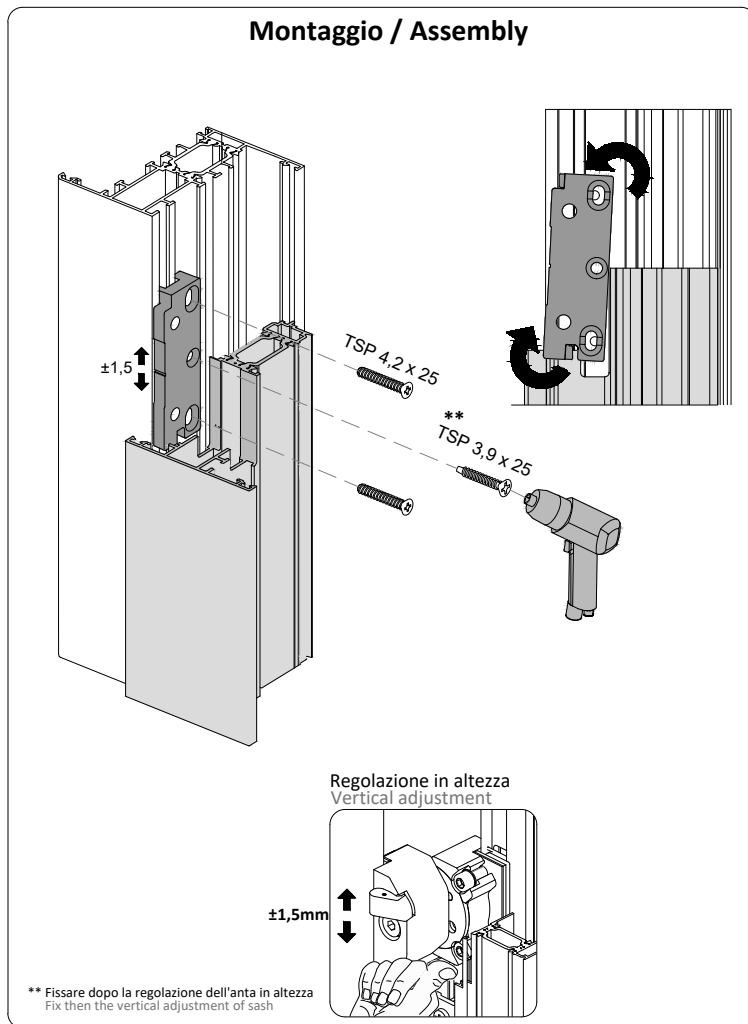

SCHEDA TECNICA DI MONTAGGIO

EasyPivot

<http://www.masteritaly.com>

CERNIERA A FRIZIONE PER FINESTRE BILICO ORIZZONTALI E VERTICALI
FRICTION HINGE FOR HORIZONTAL AND VERTICAL PIVOT WINDOWS

Per Camera Erre - For Erre groove

Kit cerniere orizzontale con blocco
Hinges kit for horizontal with lock
3700

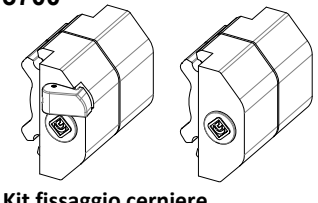

Kit cerniere verticale senza blocco
Hinges kit for vertical without lock
3700.10

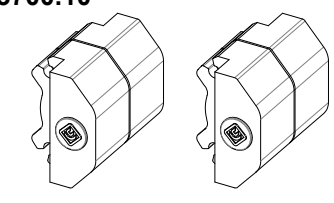

Kit fissaggio cerniere
Fixing hinges kit
3711

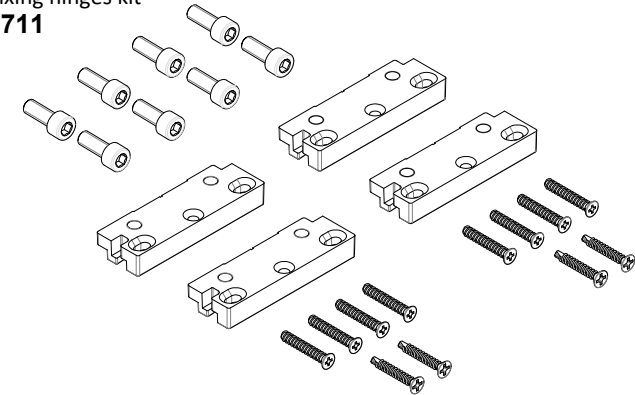

Kit chiusura perimetrale
Multi-point locking kit
3711.10

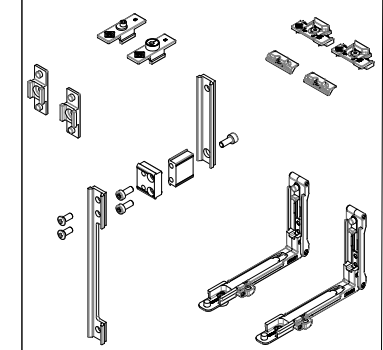

Kit chiusura supp. orizzontale
Additional locking kit for horizontal
3711.20

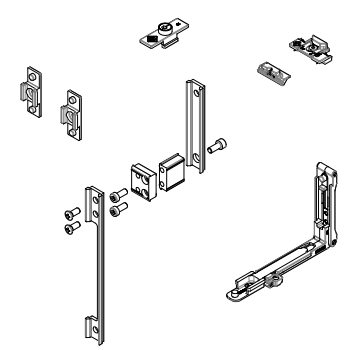

Distanziale di fissaggio di riporto
Fastening joint for profile
3711.40

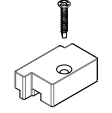

Ogni 500 mm (min. 2 per lato)
Every 500 mm (min. 2 for side)

Riferimento nodo sistema ERRE
ERRE system section referment

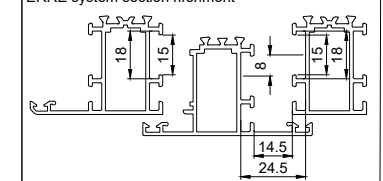

Kit chiusura supp. verticale
Additional locking kit for vertical
3711.30

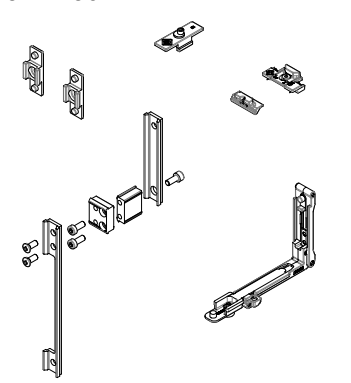

Norma di riferimento Europea UNI EN 13126-1:2006 / 13126-9:2006
Certified according to European Standard UNI EN 13126-1:2006 / 13126-9:2006

Hor.	5	120	0	1	4	-	9/1	1400x1400
Ver.	5	80	0	1	4	-	9/3	1400x1400
Categoria d'uso	Durabilità	Massa	Resistenza fuoco	Sicurezza di utilizzo	Resistenza alla corrosione	Resistenza effrazione	Applicazione	Dimensione di prova
Category of use	Durability	Mass	Fire resistance	Safety in use	Corrosion resistance	Security	Applicable part	Test size

Anta - Sash

Lavorazioni / Machining

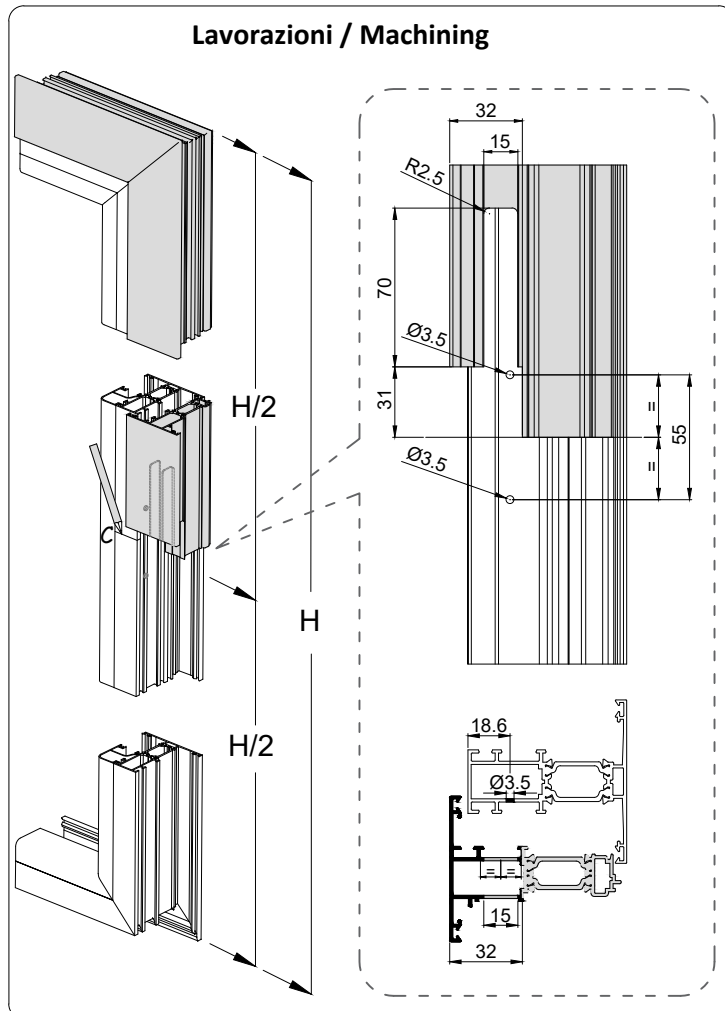

Montaggio / Assembly

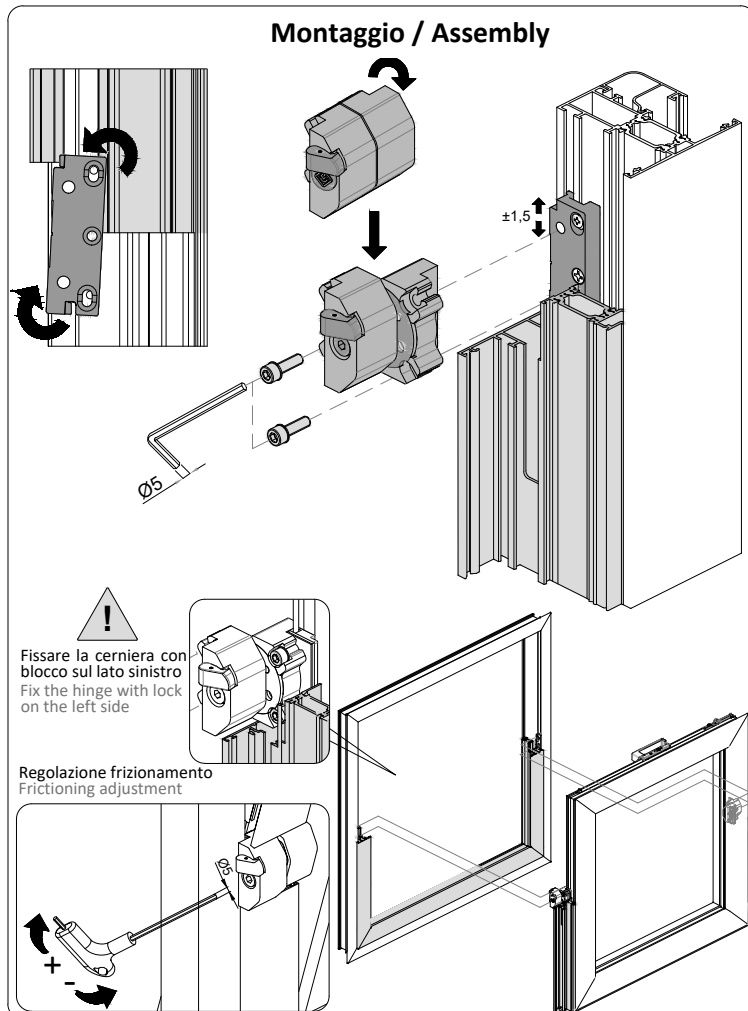

Section 1

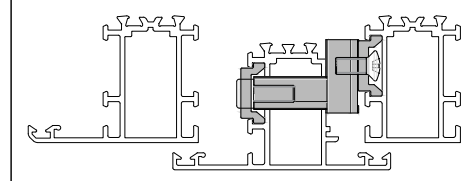

Section 2A

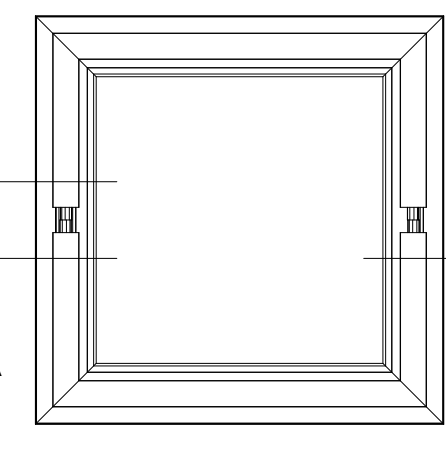
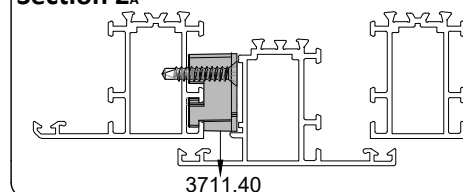

Section 2B



Diagramma di carico - Application range

Horizontal



Vertical

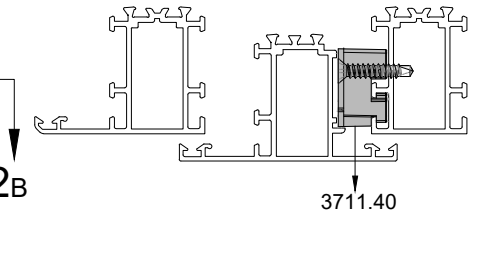
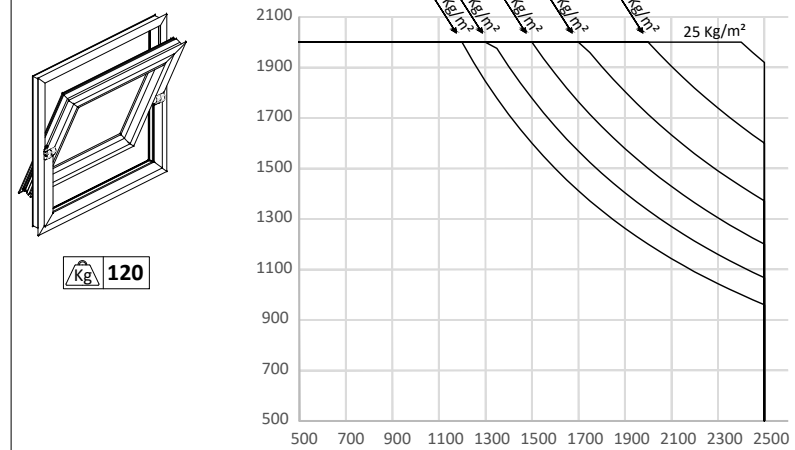
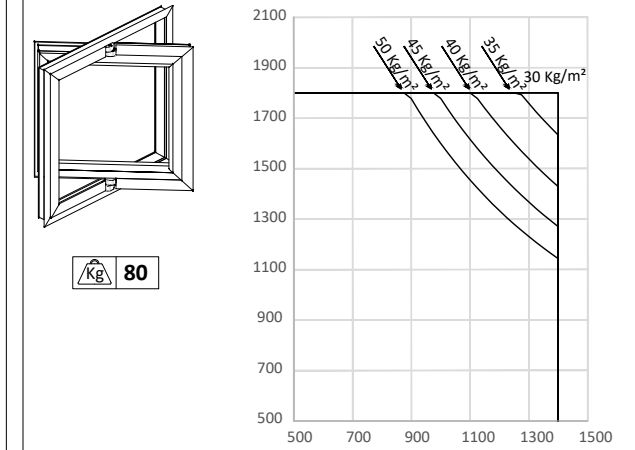

Horizontal Pivot Window

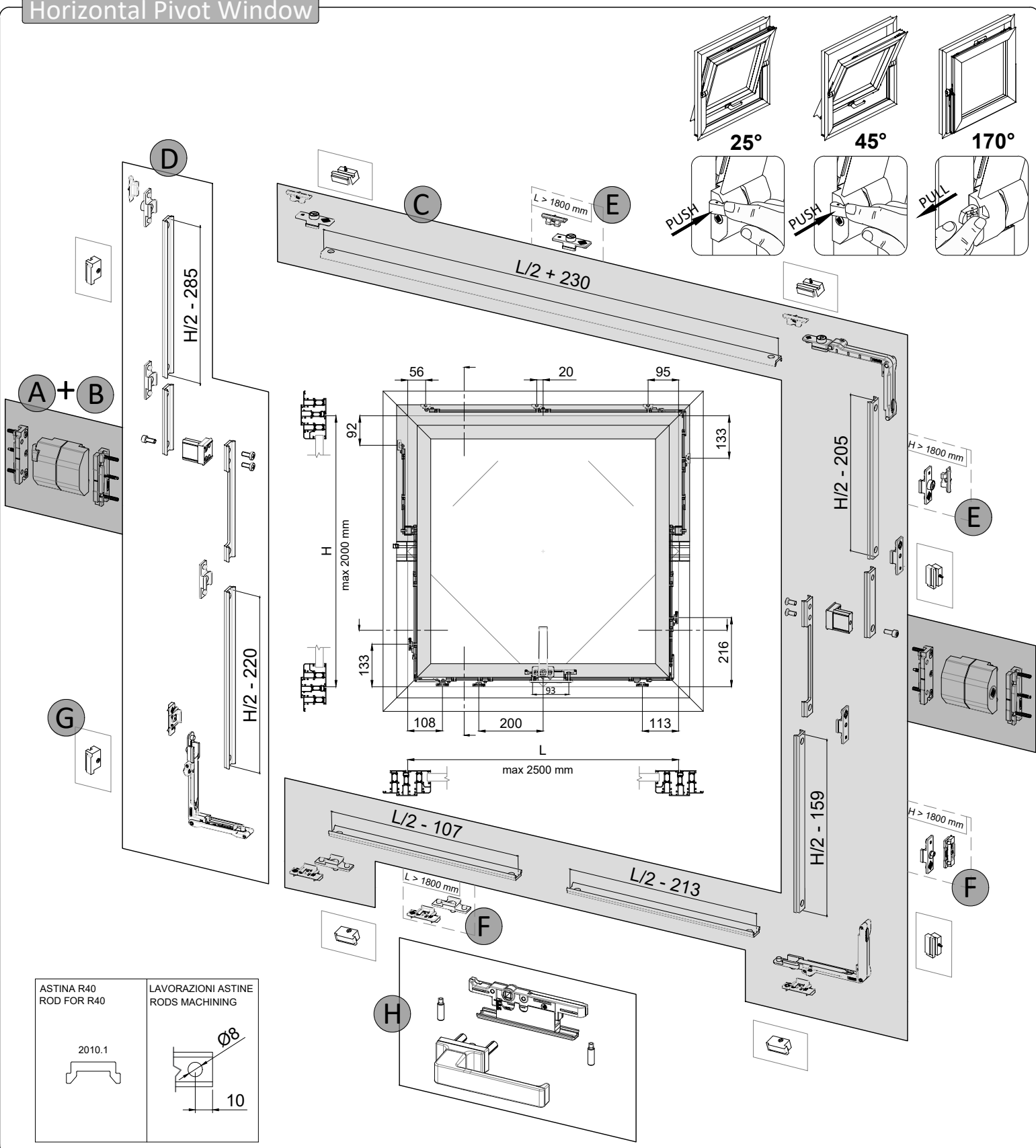

Vertical Pivot Window

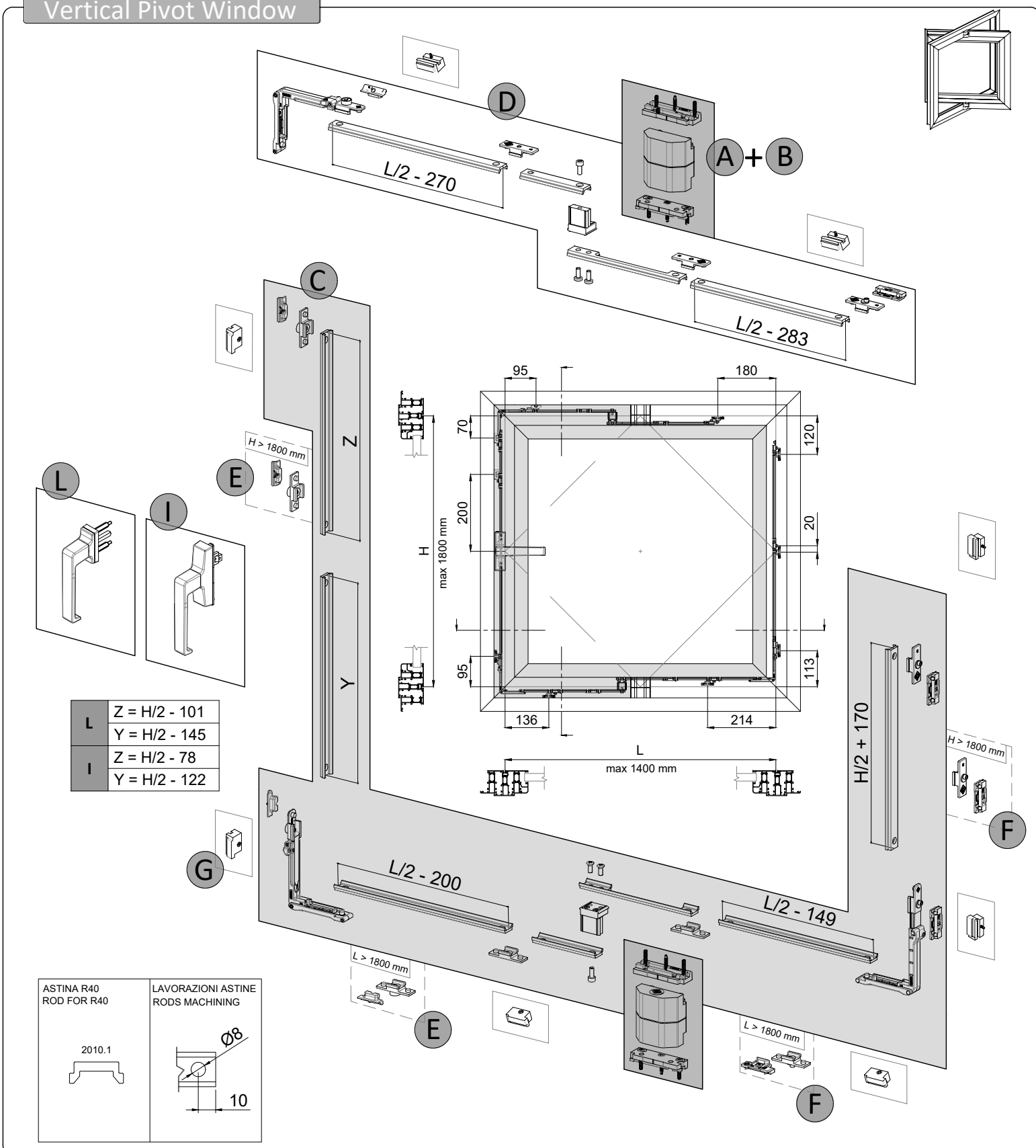

Distinta accessori / Accessories list

H 2000	A	3700	1 cp	A	3700	1 cp
	B	3711	1 pz	B	3711	1 pz
	C	3711.10	1 pz	C	3711.10	1 pz
	D	3711.20	1 pz	D	3711.20	1 pz
	E	4207.2 + 4248.12	1 pz	E	4207.2 + 4248.12	2 pz
	F	4207.11 + 4248.13	1 pz	F	4207.11 + 4248.13	2 pz
	G	3711.40	10 pz	G	3711.40	12 pz
H 0081	A	3700	1 cp	A	3700	1 cp
	B	3711	1 pz	B	3711	1 pz
	C	3711.10	1 pz	C	3711.10	1 pz
	G	3711.40	8 pz	D	3711.20	1 pz
L 550	A	3700	1 cp	A	3700	1 cp
	B	3711	1 pz	B	3711	1 pz
	C	3711.10	1 pz	C	3711.10	1 pz
	G	3711.40	8 pz	D	3711.20	1 pz
L 1800	A	3700	1 cp	A	3700	1 cp
	B	3711	1 pz	B	3711	1 pz
	C	3711.10	1 pz	C	3711.10	1 pz
	G	3711.40	8 pz	D	3711.20	1 pz
L 2500	A	3700	1 cp	A	3700	1 cp
	B	3711	1 pz	B	3711	1 pz
	C	3711.10	1 pz	C	3711.10	1 pz
	G	3711.40	8 pz	D	3711.20	1 pz

Maniglie
Handles

3070	3072	3100 - 3100.1	4207.2 + 4248.12

Altri accessori
Other accessories

3626.2	6420E.XX	4207.11 + 4248.13

Distinta accessori / Accessories list

H 1800	A	3700.10	1 cp	A	3700.10	1 cp
	B	3711	1 pz	B	3711	1 pz
	C	3711.10	1 pz	C	3711.10	1 pz
	D	3711.30	1 pz	D	3711.30	1 pz
	E	4207.2 + 4248.12	1 pz	E	4207.2 + 4248.12	2 pz
	F	4207.11 + 4248.13	1 pz	F	4207.11 + 4248.13	2 pz
	G	3711.40	10 pz	G	3711.40	12 pz
H 1000	A	3700.10	1 cp	A	3700.10	1 cp
	B	3711	1 pz	B	3711	1 pz
	C	3711.10	1 pz	C	3711.10	1 pz
	G	3711.40	8 pz	D	3711.30	1 pz
H 055	A	3700.10	1 cp	A	3700.10	1 cp
	B	3711	1 pz	B	3711	1 pz
	C	3711.10	1 pz	C	3711.10	1 pz
	G	3711.40	8 pz	D	3711.30	1 pz
L 550	A	3700.10	1 cp	A	3700.10	1 cp
	B	3711	1 pz	B	3711	1 pz
	C	3711.10	1 pz	C	3711.10	1 pz
	G	3711.40	8 pz	D	3711.30	1 pz
L 1000	A	3700.10	1 cp	A	3700.10	1 cp
	B	3711	1 pz	B	3711	1 pz
	C	3711.10	1 pz	C	3711.10	1 pz
	G	3711.40	8 pz	D	3711.30	1 pz
L 1400	A	3700.10	1 cp	A	3700.10	1 cp
	B	3711	1 pz	B	3711	1 pz
	C	3711.10	1 pz	C	3711.10	1 pz
	G	3711.40	8 pz	D	3711.30	1 pz

Maniglie
Handles

3070	3072	3100 - 3100.1	3628 - 3628.2	4207.2 + 4248.12

Altri accessori
Other accessories

6015 - 6011.10	6061	6018	6111.14	4207.11 + 4248.13