

**REGOLAZIONE
ADJUSTMENT**

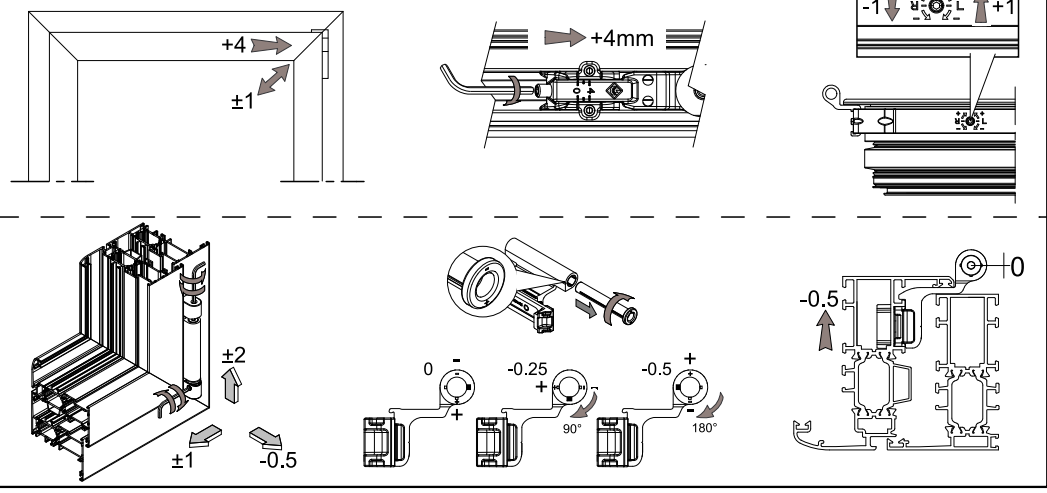

140 Kg

	2700	50	41	35	30	26	23	21	19	17	16	15	14	13	12
	2600	50	43	36	31	27	24	22	20	18	17	15	14	13	13
	2500	50	45	37	32	28	25	22	20	19	17	16	15	14	13
	2400	50	47	39	33	29	26	23	21	19	18	17	16	15	14
	2300	50	49	41	35	30	27	24	22	20	19	17	16	15	14
	2200	50	50	42	36	32	28	25	23	21	20	18	17	16	15
	2100	50	50	44	38	33	30	27	24	22	21	19	18	17	14
	2000	50	50	47	40	35	32	28	25	23	22	20	19	18	15
	1900	50	50	49	42	37	33	29	27	25	23	21	20	17	16
	1800	50	50	50	44	39	35	31	28	26	24	22	19	18	16
	1700	50	50	50	47	41	37	33	30	27	25	21	20	19	17
	1600	50	50	50	50	44	39	35	32	29	24	23	21	20	15
	1500	50	50	50	50	47	41	37	34	31	26	24	22	18	13
	1400	50	50	50	50	50	44	40	36	30	28	26	20	15	14
	1300	50	50	50	50	50	48	43	35	32	30	23	17	16	10
	1200	50	50	50	50	50	50	42	38	35	27	20	19	12	5
	1100	50	50	50	50	50	50	46	42	32	23	22	14	6	X
	1000	50	50	50	50	50	50	38	28	26	16	7	X	X	X
	900	50	50	50	50	50	50	37	34	21	10	X	X	X	X
	800	50	50	50	50	50	47	42	25	12	X	X	X	X	X
	700	50	50	50	50	50	50	16	X	X	X	X	X	X	X
	600	50	50	50	50	47	21	X	X	X	X	X	X	X	X
	500	50	50	50	50	X	X	X	X	X	X	X	X	X	X
H															
L	395	500	600	700	800	900	1000	1100	1200	1300	1400	1500	1600	1700	

Norma di riferimento Europea UNI EN 13126-1:2006 / 13126-8:2006 | Certified according to European Standard UNI EN 13126-1:2006 / 13126-8:2006

1550x1400	4	140	0	1	4	-	8	-
Dimensione di prova	Durabilità	Massa	Resistenza fuoco	Sicurezza di utilizzo	Resistenza alla corrosione	Resistenza effrazione	Applicazione	Categoria d'uso
Test size	Durability	Mass	Fire resistance	Safety in use	Corrosion resistance	Security	Applicable part	Category of use

Kit anta ribalta con AFM su cremone | Per sistemi Camera Erre
Kit for tilt and turn with AFM on the cremone bolt | For Erre Groove system

3421G.1 / 3421G.40
3421G.151 / 3421G.401
3421LG.1

Riferimento nodo sistema ERRE
ERRE system section riferiment

A08

ITA

ESP

ENG

FRA

LAVORAZIONI / MACHINING

**LAVORAZIONI ASTINE
RODS MACHINING**

Part numbers: 3072, 3077.2, 3070, 3070.2, 3100, 3101, 3077.25D/S, 3075.25D/S, 3101.25

**Maniglie
Handles**

<p>6018</p>	<p>6038 6038.20D/S</p>	<p>6015 - 6015.3 6011 - 6011.10</p>	<p>6036 - 6032.10 - 6036.3 6036.20D/S 6036.23D/S</p>	<p>6061</p>	<p>6063 6063.20</p>
<p>3072</p>	<p>3077.2 3077.25D/S</p>	<p>3070</p>	<p>3070.2 3070.25D/S</p>	<p>3100</p>	<p>3101 3101.25</p>

MASTER S.r.l. - I618F - A3 FR - 22/06/2026

Posizionamento punti chiusura kit base | Base kit locking points positioning

AFM

ANTA RIBALTA | **TILT AND TURN**

T&T

Ribalta
Tilt

Apertura
Open

Chiusura
Locking

3421G.1 / 3421G.40 / 3421G.151 / 3421G.401

AFM

MANOVRA LOGICA | **TILT BEFORE TURN**

TBT

Apertura
Open

Ribalta
Tilt

Chiusura
Locking

3421LG.1

- ⚠ OBBLIGATORIO PER PESI > 80kg
- ⚠ MANDATORY FOR WEIGHT > 80kg
- ⚠ OBLIGATOIRE POUR LES POIDS > 80 kg
- ⚠ OBLIGATORIO DE PESO > 80kg

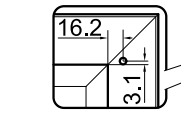
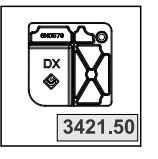
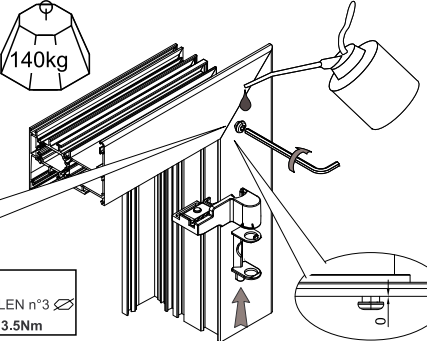

Ø3.5
Utensili utilizzati ALLEN n°3
Coppia / Torque MAX 3.5Nm

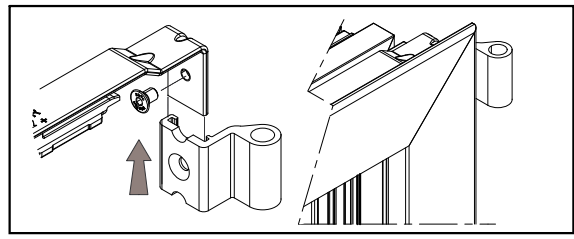

* Perno microventilazione integrata
Da abbinare a 3421.39
Built-in microventilation pin
In combination with 3421.39

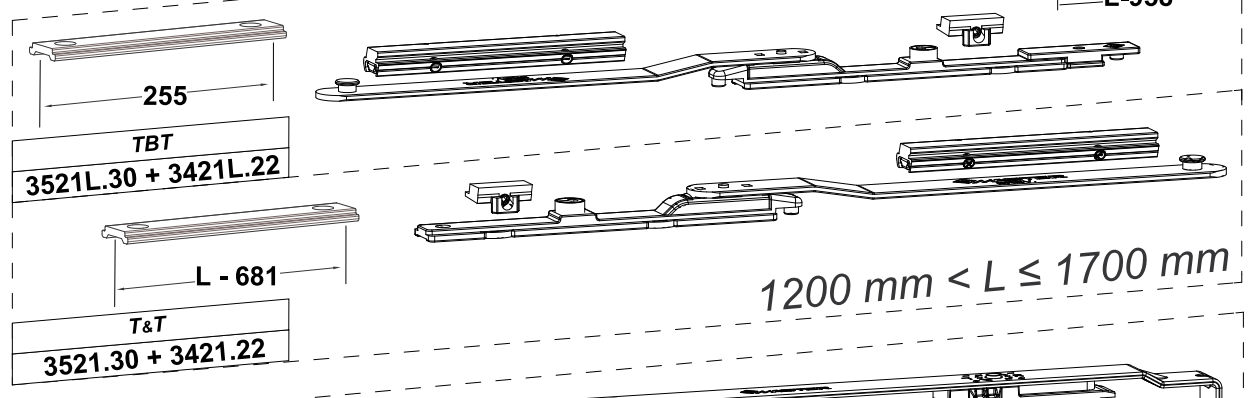

1200 mm < L ≤ 1700 mm

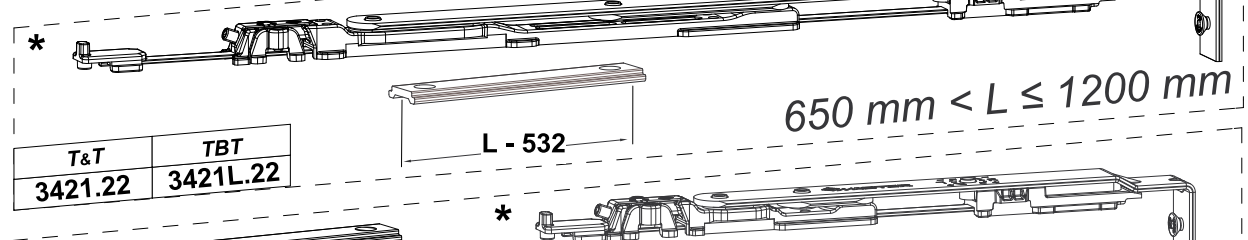

650 mm < L ≤ 1200 mm

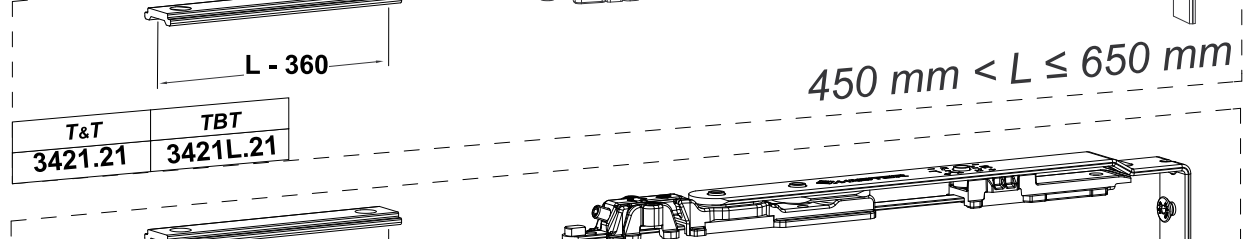

450 mm < L ≤ 650 mm

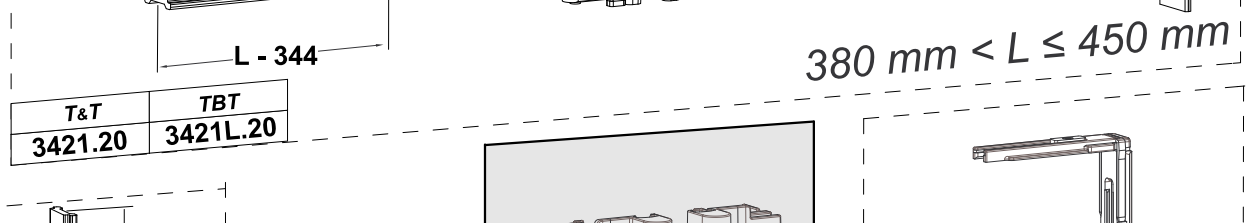

380 mm < L ≤ 450 mm

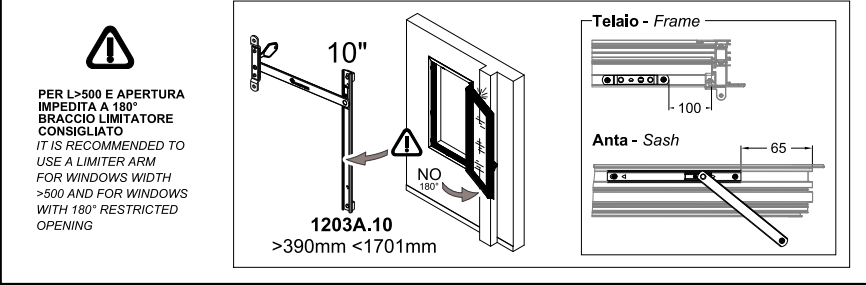

PER L>500 E APERTURA
IMPEBITA A 180°
BRACCIO LIMITATORE
CONSIGLIATO
IT IS RECOMMENDED TO
USE A LIMITER ARM
FOR WINDOWS WIDTH
>500 AND FOR WINDOWS
WITH 180° RESTRICTED
OPENING

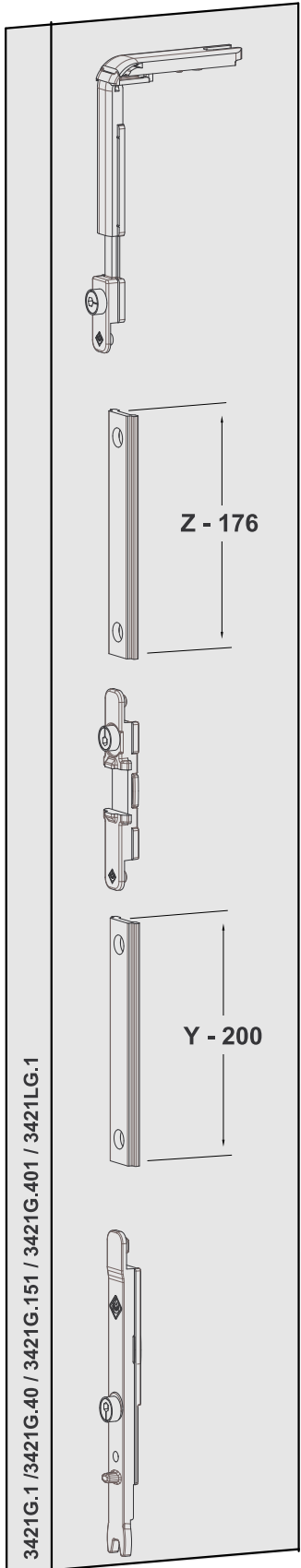
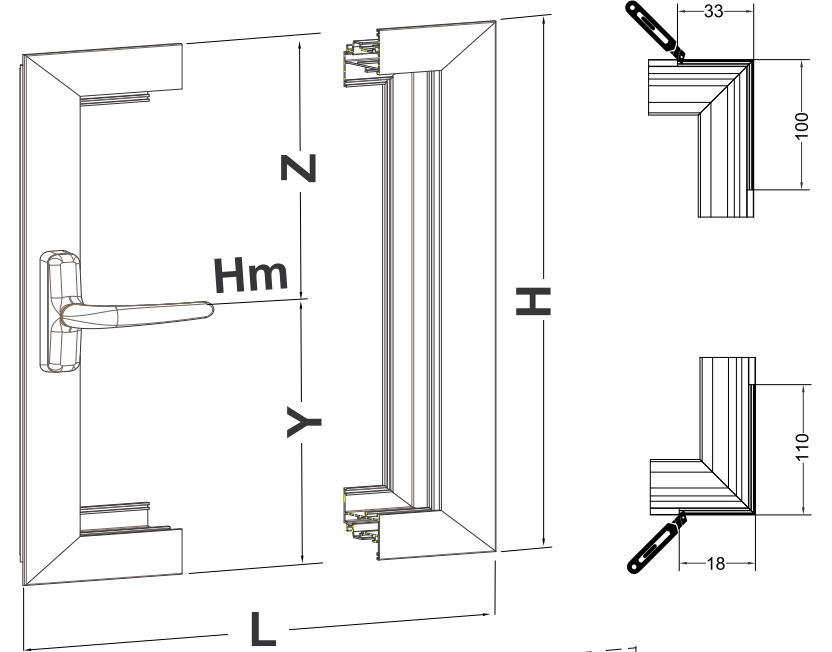
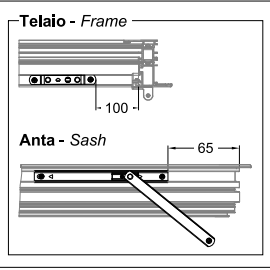

con / with 3421.32	Z - 250
senza / without 3421.3	Z - 197

con / with 3421.32	Z - 253
senza / without 3421.3	Z - 200

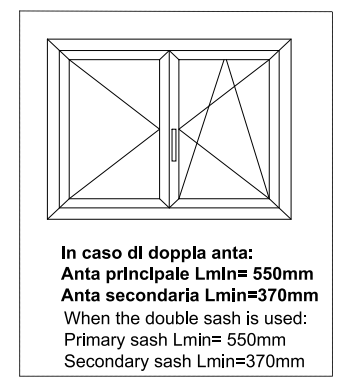
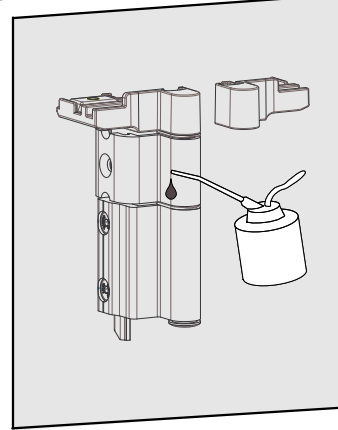

In caso di doppia anta:
Anta principale Lmin= 550mm
Anta secondaria Lmin=370mm
When the double sash is used:
Primary sash Lmin= 550mm
Secondary sash Lmin=370mm

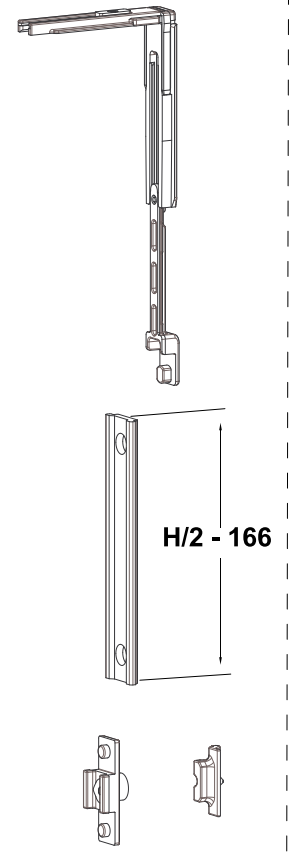
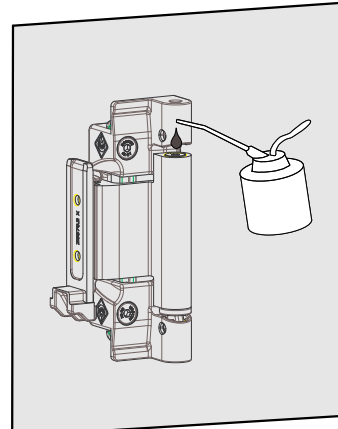

H/2 - 166

H > 1400 mm
3421.31

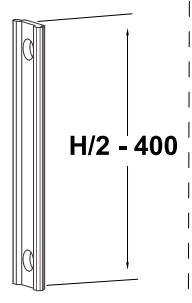

H/2 - 400

H > 2200 mm
3421.32

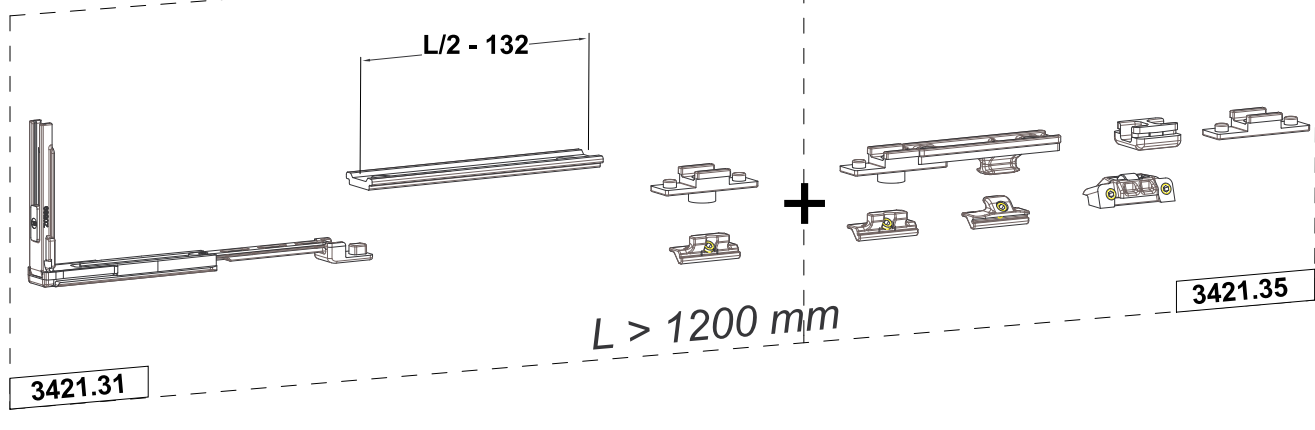

L > 1200 mm

3421.35

3421.31

3421G.1 / 3421G.40 / 3421G.151 / 3421G.401 / 3421LG.1