

6397.19 - 6397.20 - 6397.21
6397.12

MANIGLIE AD INCASSO PER FAST LOCK
FAST LOCK EMBEDDED HANDLE

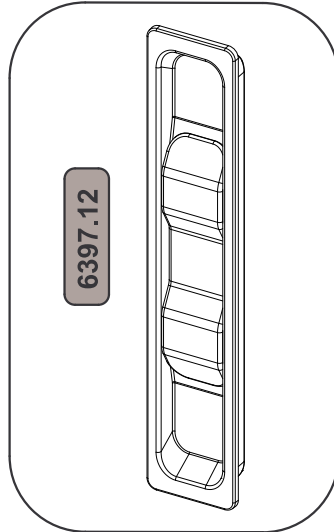

VERSIONI
VERSION

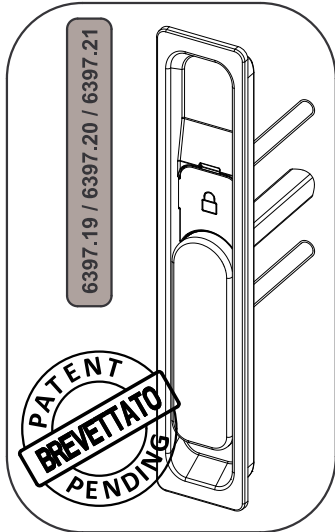
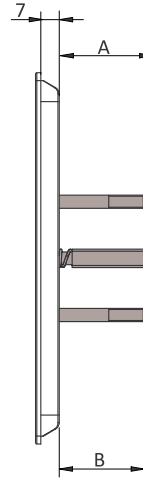

LAVORAZIONI
MACHINING

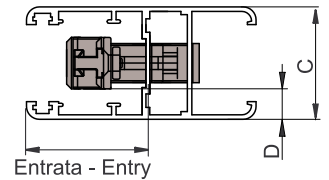
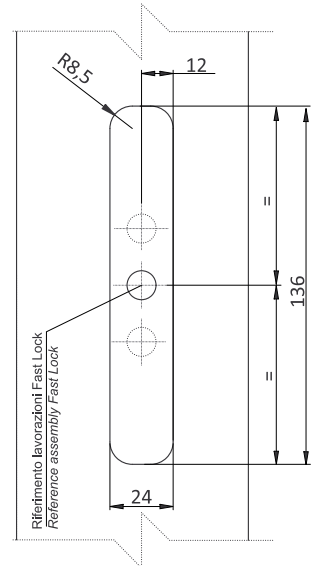

Art.	A	B	C
6397.19	21,5	22	30-45mm
6397.20	35,5	32	45-70mm
6397.21	45,5	45,5	56-90mm



S = D-7mm

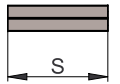

MONTAGGIO / ASSEMBLY

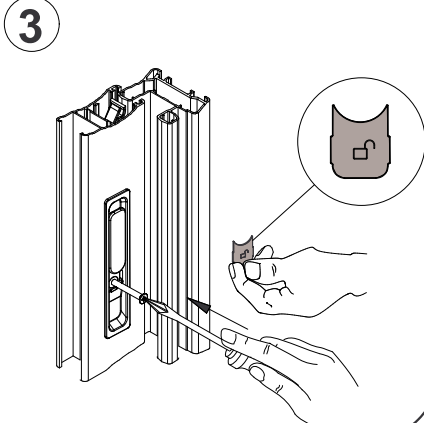
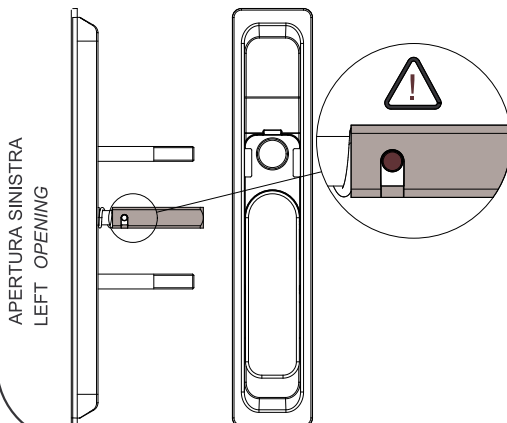
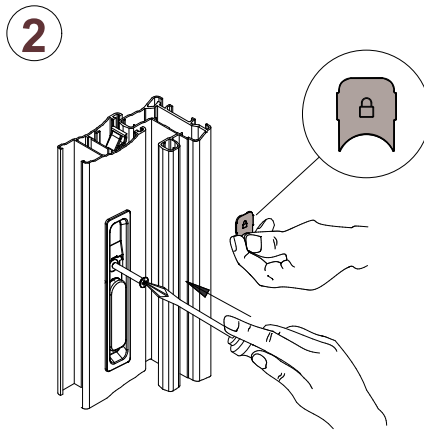
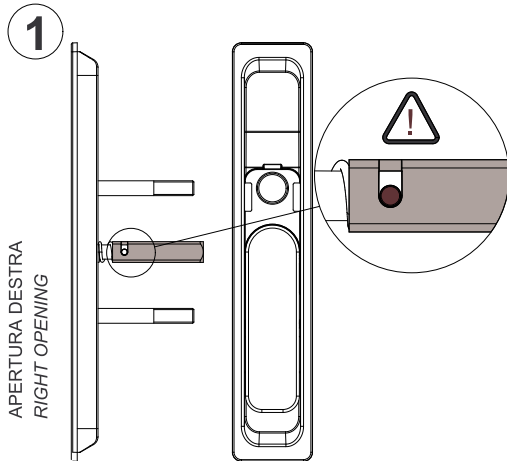

VERSIONE ABBINATA
COMBINED VERSION

