

Dimensioni e portate
Dimensions and weights

130Kg - 180° **A3310.50**

Obbligatorio A3310.50 con soglie ribassate
Mandatory A3310.50 with low threshold

Consigliato A3310.50 per portate >110Kg
Recommended A3310.50 with weights >110Kg

2500	50	42	35	30	26	23	21	19	17	16	15	14	
2400	50	43	36	31	27	24	22	20	18	17	15	14	
2300	50	45	38	32	28	25	23	21	19	17	15	15	
2200	50	47	39	34	30	26	24	21	20	18	16	16	
2100	50	50	41	35	31	28	25	23	21	19	17	17	
2000	50	50	43	37	33	29	26	24	22	20	18	17	
1900	50	50	46	39	34	30	27	25	23	21	19	18	
1800	50	50	48	41	36	32	29	26	24	22	20	17	
1700	50	50	50	44	38	34	31	28	25	24	20	18	
1600	50	50	50	46	41	36	33	30	27	23	21	20	
1500	50	50	50	50	43	39	35	32	29	24	21	21	
1400	50	50	50	50	46	41	37	34	28	26	22	19	
1300	50	50	50	50	44	40	33	30	28	24	17		
1200	50	50	50	50	48	39	35	33	25	21			
1100	50	50	50	50	47	43	39	30	22	19			
1000	50	50	50	50	47	35	26	24	15	7			
900	50	50	50	50	50	35	32	19	9	X	X		
800	50	50	50	50	50	43	39	24	11	X	X		
700	50	50	50	50	50	15	X	X	X	X	X		
600	50	50	50	50	43	19	X	X	X	X	X		
550	50	50	50	50	X	X	X	X	X	X	X		
H	L	470	500	600	700	800	900	1000	1100	1200	1300	1400	1500

150Kg - 90° **A3310.50**

Obbligatorio A3310.50
Mandatory A3310.50

2700	50	44	37	32	28	25	22	20	19	17	16	15	14	13
2600	50	46	38	33	29	26	23	21	19	18	16	15	14	14
2500	50	48	40	34	30	27	24	22	20	18	17	16	15	14
2400	50	50	42	36	31	28	25	23	21	19	18	17	16	15
2300	50	50	43	37	33	29	26	24	22	20	19	17	16	15
2200	50	50	45	39	34	30	27	25	23	21	19	18	17	16
2100	50	50	48	41	36	32	29	26	24	22	20	19	18	15
2000	50	50	50	43	38	33	30	27	25	23	21	20	19	16
1900	50	50	50	45	39	35	32	29	26	24	23	21	18	17
1800	50	50	50	48	42	37	33	30	28	26	24	20	19	18
1700	50	50	50	50	44	39	35	32	29	27	23	21	20	19
1600	50	50	50	47	42	38	34	31	26	24	23	21	17	14
1500	50	50	50	50	44	40	36	33	28	26	24	19	14	11
1400	50	50	50	50	50	44	43	39	32	30	28	21	16	15
1300	50	50	50	50	50	46	38	35	32	25	18	17	11	6
1200	50	50	50	50	50	45	41	38	23	21	20	13	6	
1100	50	50	50	50	50	49	45	27	25	23	15	6	X	
1000	50	50	50	50	50	50	33	30	28	17	7	X	X	
900	50	50	50	50	50	40	36	22	10	X	X	X	X	
800	50	50	50	50	50	45	27	11	X	X	X	X	X	
700	50	50	50	50	50	17	X	X	X	X	X	X	X	
600	50	50	50	50	19	X	X	X	X	X	X	X	X	
550	50	50	50	50	X	X	X	X	X	X	X	X	X	
H	L	470	600	600	700	800	900	1000	1100	1200	1300	1400	1500	1700

Es. IT Anta eseguibile con spessore vetro Max 20 mm
EN Sash size executable with Max glass thickness 20 mm

X IT Dimensione non eseguibile
EN Not feasible

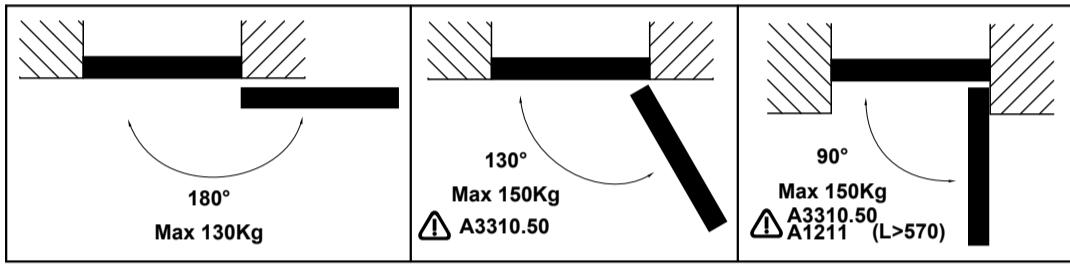

Per apertura impedita a 180° è obbligatorio braccio limit.
For windows with 180° restricted opening mandatory use a limiter arm
A1211 (L>570)

Kit anta ribalta a scomparsa Automatica - Logica
Hidden kit for Automatic tilt and turn - Logica

Per sistemi Camera Europea
For Euro Groove system

Kit base
Base kit

Fr. ty.	Cod.
F2	3327LG.1
F1	

24V

Riferimento nodo Camera Europea
Euro groove section riferiment

Frame type	B	C	D	E
F2	14	4	18	1.5
	13.5	3.2	16.8	2.4
F1	12	2.9	15	1.5
	10	4.2	14.5	1.5

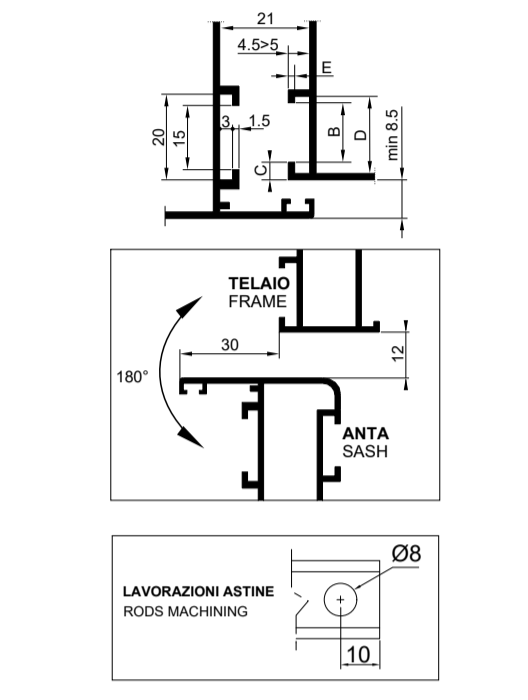

Braccio corto
Short arm

Fr. ty.	Cod.
F2	3304L.20S 3304L.20D
F1	3303L.20S 3303L.20D

Braccio lungo
Long arm

Fr. ty.	Cod.
F2	3304L.21S 3304L.21D
F1	3303L.21S 3303L.21D

Cerniera inferiore
Bottom hinge

Fr. ty.	Cod.
F2	3304S 3304D
F1	3303S 3303D

Inversioni di apertura DX-SX | Direction of opening of Right-Left

- IT Pomolo Fisso
- EN Fixed knob
- FR Poignée Fixe
- ES Pomo fijo

- IT Ruotatore di 180° il riscontro avvitato sulla serratura
- EN Rotate 180° the counterplate screwed on the lock
- FR Tourner de 180° la gâche vissée sur la serrure
- ES Girar 180° el cerradero enroscado en la cerradura

MASTER S.r.l. - I697A - A3
29/02/2024

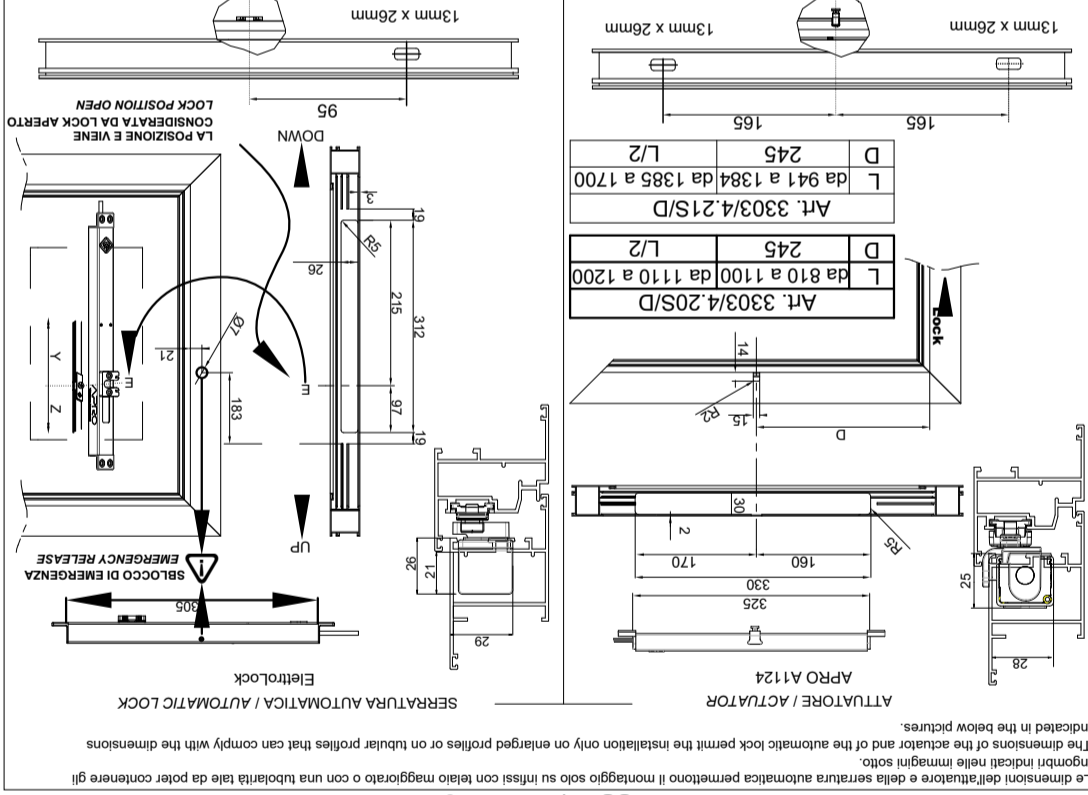

Indicazioni di montaggio | Mounting Indication

Art. complementari | Art. complementary

Fr. ty.	Cod.
F2	3550L.30
F1	

- ES Kit puntos de cierre
- FR Kit points de fermeture
- EN Kit locking points
- IT Kit chiusura verticale e orizzontale

3400G.31 (H-1400 - L- > 1200)

- ES Baje el cierre horizontal
- FR Abaissez fermeture horizontale
- EN Lower horizontal closing
- IT Chiusura orizzontale inferiore

3400.35 (L- > 1200 mm)

- ES Compas adicional
- FR Bras supplémentaire
- EN Additional arm
- IT Braccio supplementare

3550L.30 (L- > 1200 mm)

- ES Soporte de hoja
- FR Support vantail
- EN Shutter support
- IT Supporto anta

3310.50

Configurazioni | Configurations

Portate > 130kg Art. 3301.50 Obbligatorio | Weight > 130kg Art. 3301.50 obligatory

Portata	Configurazione	Portata	Configurazione
2700	3327LG.1 + 3303L/4L.20S/D + 3400G.31 + 3303/4S/D	2200	3327LG.1 + 3303L/4L.20S/D + 3400G.31 + 3303/4S/D
2000	3327LG.1 + 3303L/4L.20S/D + 3400G.31 + 3303/4S/D	1400	3327LG.1 + 3303L/4L.20S/D + 3400G.31 + 3303/4S/D
1700	3327LG.1 + 3303L/4L.20S/D + 3400G.31 + 3303/4S/D	700	3327LG.1 + 3303L/4L.20S/D + 3400G.31 + 3303/4S/D

N.D. Controllare tabella diagramma di carico
Check the load capacity chart see

TELAIO - FRAME

MONTAGGIO CERNIERE TELAI HINGE FRAME ASSEMBLY

Valido per cerniera inferiore e superiore
Valid for bottom and top hinge

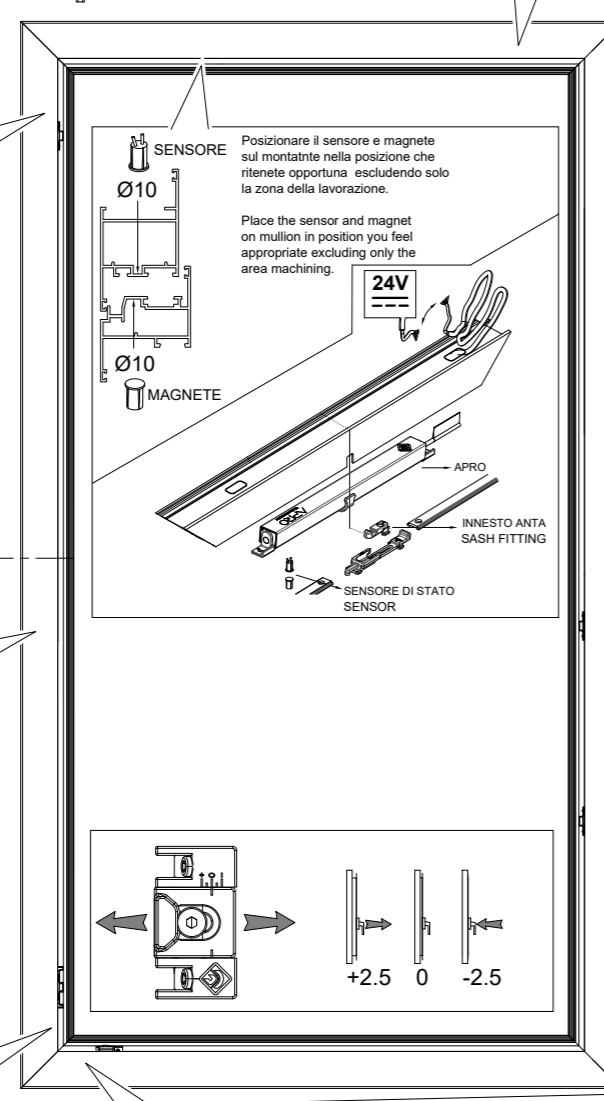
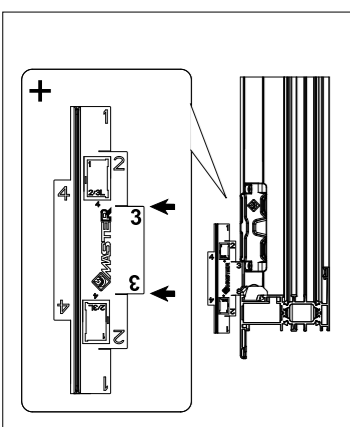
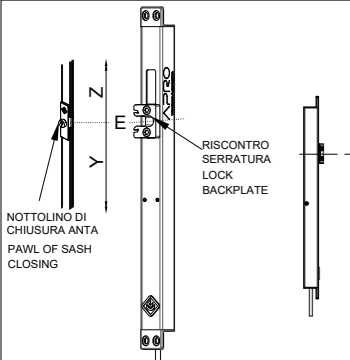
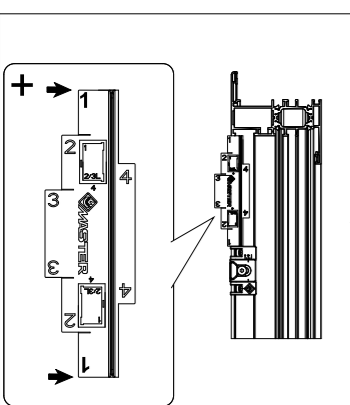
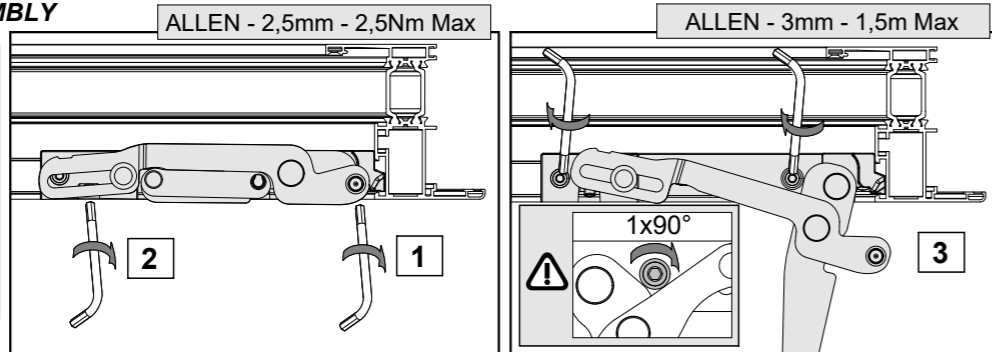

Per eventuali chiarimenti chiedere info al nostro Uff. Tecnico tel. 080.4959823
For other information contact our technical office at: +39.08.04.95.98.23

ANTA - SASH

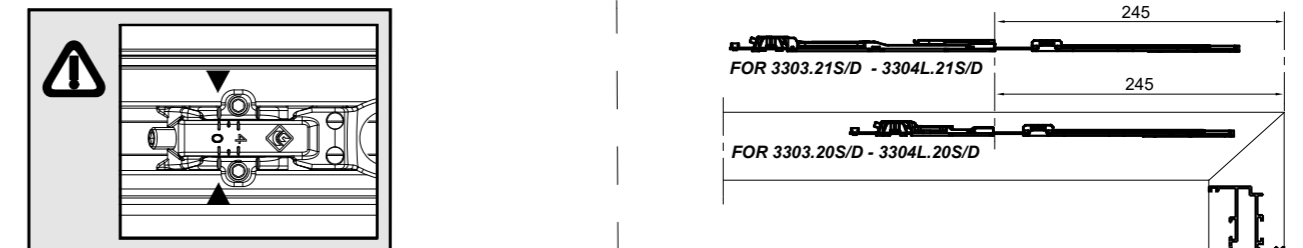

3400F.31 H > 1400 mm
H/2-166

3400F.32 H > 2200mm
H/2-400

Art. 3303/4L.20S/D

L = da 810 a 1110
A = 154
B = L - 693

L = da 1111 a 1200
A = L/2 - 97
B = L/2 - 442

Art. 3303/4L.21S/D

L = da 941 a 1379
A = 154
B = L - 820

L = da 1380 a 1700
A = L/2 - 97
B = L/2 - 571

L = da 1380 a 1700
A = L/2 - 519
B = L/2 - 571
C = 255

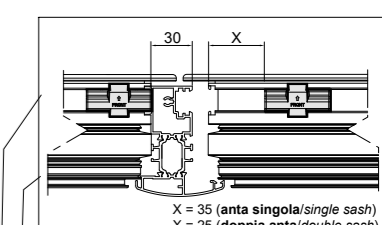
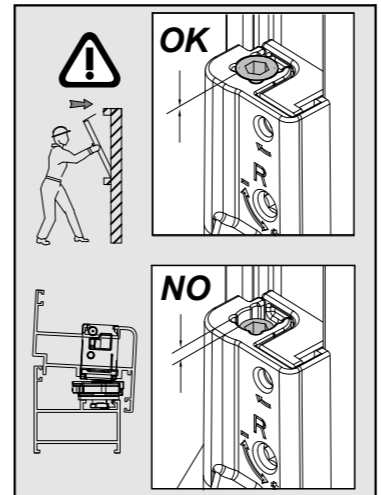

PER L > 500 E APERTURA IMPEDITA A 180° BRACCIO LIMITATORE OBBLIGATORIO
IT IS OBLIGATORY TO USE A LIMITER ARM FOR WINDOWS WIDTH > 500 AND FOR WINDOWS WITH 180° RESTRICTED OPENING

Cod. A1211

3400F.31/3400.35 L/2-132
L > 1200mm

Indicazioni di montaggio / Assembling

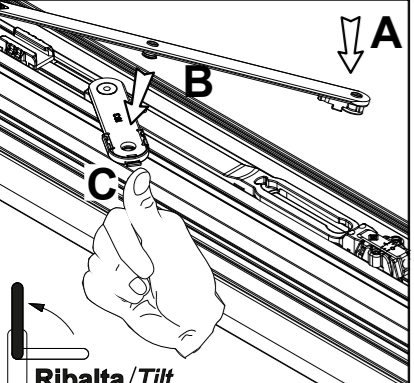

MANOVRA LOGICA TILT BEFORE TURN	
COD.	NODO
3304L.21S/D A01 - A05	
3303L.21S/D	A03
ANTA RIBALTA TILT AND TURN	
COD.	NODO
3304.21S/D A01 - A05	
3303.21S/D	A03

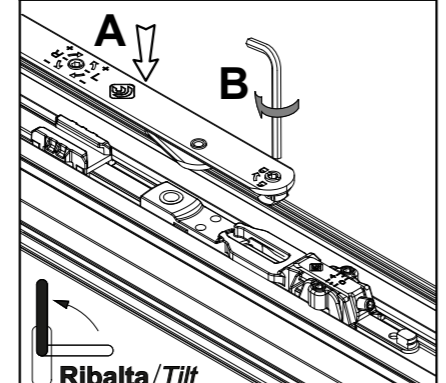

MANOVRA LOGICA TILT BEFORE TURN	
COD.	NODO
3304L.20S/D A01 - A05	
3303L.20S/D	A03
ANTA RIBALTA TILT AND TURN	
COD.	NODO
3304.20S/D A01 - A05	
3303.20S/D	A03

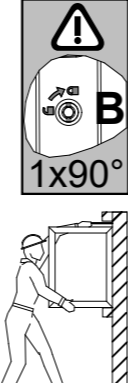

Regolazioni / Adjustments

