



HARDWARE FOR WINDOWS AND DOORS

<http://www.masteritaly.com>



Karma Martelline Minimali Universali

<http://www.masteritaly.com>

SCHEDA TECNICA DI MONTAGGIO



ART.	DESCRIZIONE	Y
A3091.A	Martellina Handle	26mm
A3091.1A		32mm
A3091.2A		38mm

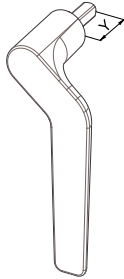

ART.	DESCRIZIONE	Y
A3091.AS	Martellina SX Handle SX	26mm
A3091.1AS		32mm
A3091.2AS		38mm

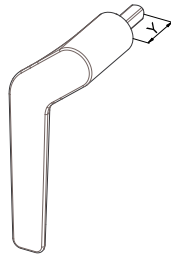

ART.	DESCRIZIONE	Y
A3091.AD	Martellina DX Handle DX	26mm
A3091.1AD		32mm
A3091.2AD		38mm

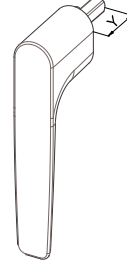

ART.	DESCRIZIONE	Y
A3091.60	Martellina ovale Oval handle	26mm
A3091.61		32mm
A3091.62		38mm

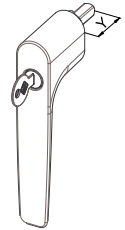

ART.	DESCRIZIONE	Y
A3091.40	Martellina chiave a cifratura mista	26mm
A3091.41	Handle with mixed encryption key	32mm
A3091.42		38mm
A3091.40K	Martellina chiave a cifratura unica	26mm
A3091.41K	Handle with unique encryption key	32mm
A3091.42K		38mm

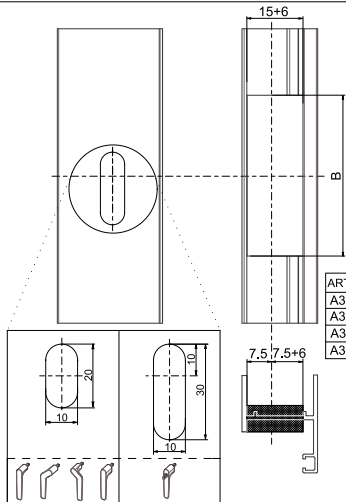

ARTICOLO	B
A3627.xx	54mm
A3628.xx	60mm
A3630.xx	60mm
A3631.xx	60mm

CE

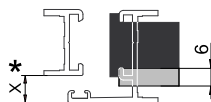

ART.	DESCRIZIONE	X	Y	NODO
A3630.60	Kit di fissaggio CE Euro groove fixing kit	8-10mm	26mm	A01-A03-A05-A20-A21-A22

R40

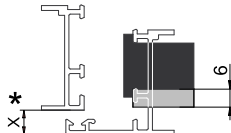

ART.	DESCRIZIONE	X	Y	NODO
A3630.61	Kit di fissaggio R40 R40 fixing kit	8mm	26mm	A08-A23

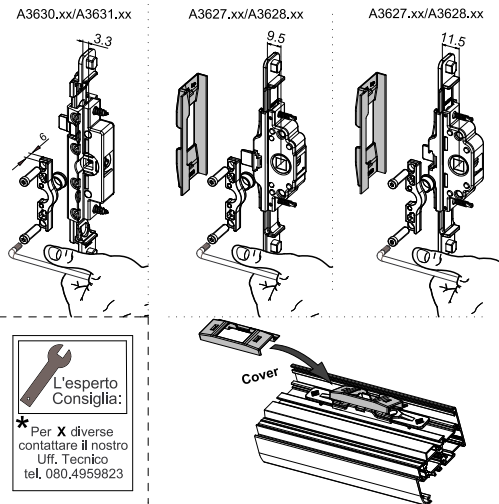

L'esperto Consigliata:
* Per X diverse contattare il nostro Uff. Tecnico tel. 080.4959823

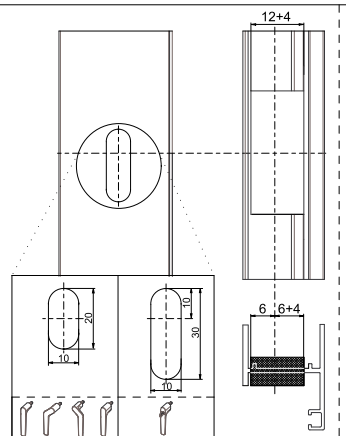

FERRAMENTA A NASTRO

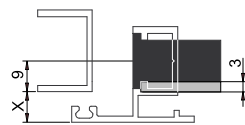
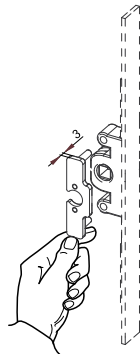

ART.	DESCRIZIONE	X	Y
A3630.70	Kit di fissaggio cava 16 e PVC Cava 16 and PVC fixing kit	7-9mm	26mm
A3630.71		9-11mm	
A3630.72		11-13mm	
A3630.73		13-15mm	
A3630.74		15-17mm	
A3630.75		17-19mm	
A3630.76	19-21mm	32mm	

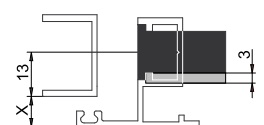

ART.	DESCRIZIONE	X	Y
A3630.72	Kit di fissaggio cava 16 e PVC Cava 16 and PVC fixing kit	7-9mm	26mm
A3630.73		9-11mm	
A3630.74		11-13mm	
A3630.75		13-15mm	
A3630.76		15-17mm	
A3630.77		17-19mm	
A3630.78	19-21mm	38mm	

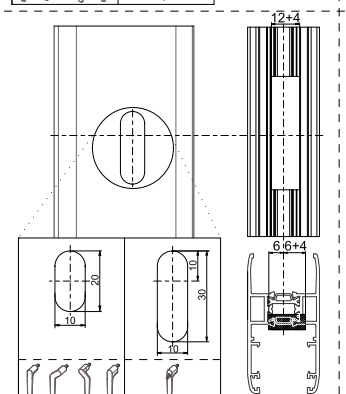

FASTLOCK

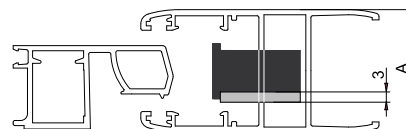
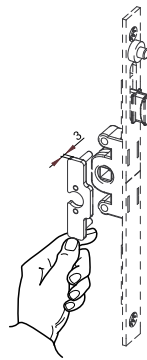

ART.	DESCRIZIONE	A	Y
A3630.70	Kit di fissaggio Fastlock Fastlock fixing kit	32-36mm	26mm
A3630.71		36-40mm	
A3630.72		40-44mm	
A3630.73		44-48mm	
A3630.74		48-52mm	

1 Posizionare sede grano lato apertura maniglia
Place socket set screw on the handle opening side

Per Viti di fissaggio
Chiave TORX T10

2

Premere
Push

Grano di fissaggio M5x14mm

Per Grano di fissaggio
Chiave ALLEN esagonale n° 2.5

**Grezzo
Mill finish**

Verificare il corretto posizionamento
Check the correct positioning

Verificare il corretto posizionamento
Check the correct positioning

Grano di fissaggio M5x14mm

Per Grano di fissaggio
Chiave ALLEN esagonale n° 2.5

1 Posizionare sede grano lato apertura maniglia
Place socket set screw on the handle opening side

Per Viti di fissaggio
Chiave TORX T10

2

Premere
Push

Grano di fissaggio M5x10mm

Per Grano di fissaggio
Chiave ALLEN esagonale n° 2.5

4 Posizionare il cilindro con la zona squadrata
in corrispondenza del grano di fissaggio
Place the cylinder with the square area
in the socket set screw area

Grano di fissaggio M5x4mm

Per Grano di fissaggio
Chiave ALLEN esagonale n° 2.5
Coppia massima di serraggio di 3Nm
Maximum tightening torque of 3Nm

* Verificare che la serratura sia aperta (13.5mm)
13.5
Check that the lock is open (13.5mm)