

"NIX" MANIGLIA A SCOMPARSA "NIX" CONCEALED HANDLE

Y [mm]	ART.	ART. CON CHIAVE ART. WITH KEY	P [mm]
$18 \leq Y \leq 18.5$	4101	4101.10	25
$18.5 \leq Y \leq 30$	4101.1	4101.11	37
$30 \leq Y \leq 40$	4101.2	4101.12	47

Lavorazione Machining

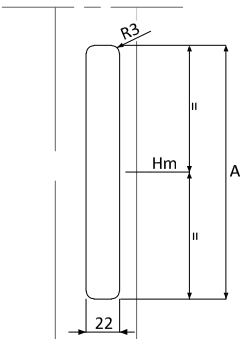

S [mm]	A [mm]
$1.3 \leq S < 2$	226
$2 \leq S \leq 2.3$	227
$2.3 < S \leq 3$	228

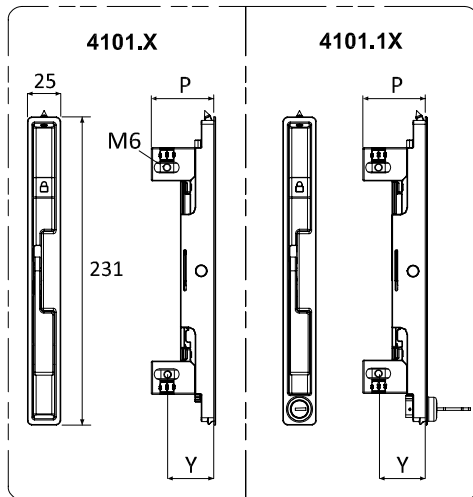
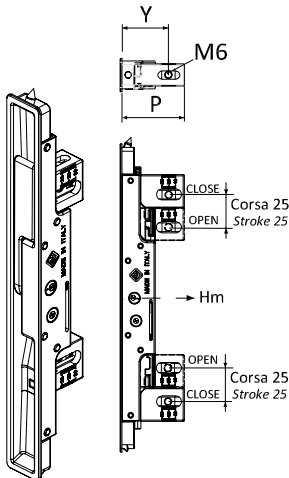

Funzionamento con aggancio laterale Operation with lateral fix

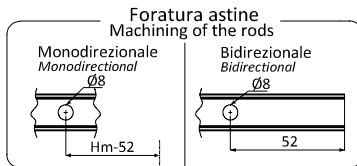
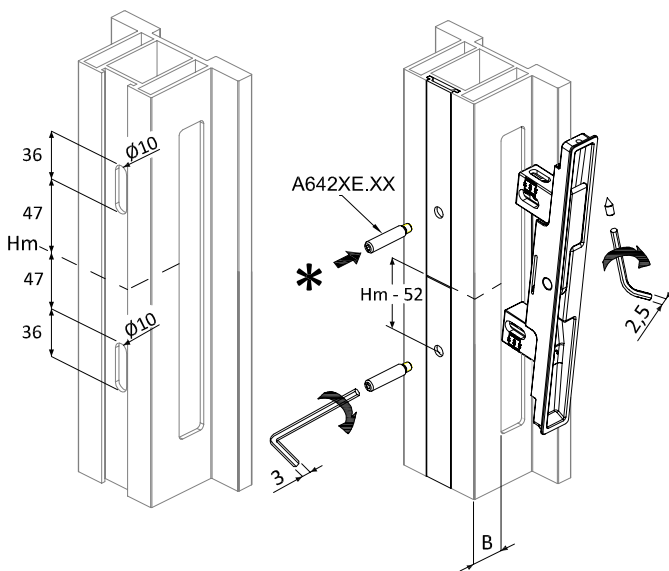



A [mm]	COD.	MATERIALE MATERIAL
$B < 3$	6420E.11	Acciaio zincato Galvanized steel
$3 \leq B < 5$	6420E.13	Acciaio zincato Galvanized steel
$5 \leq B < 8$	6420E.16	Acciaio zincato Galvanized steel
$8 \leq B < 10$	6420E.18	Acciaio zincato Galvanized steel
$10 \leq B < 14$	6420E.22	Acciaio zincato Galvanized steel
$14 \leq B < 17$	6420E.25	Acciaio zincato Galvanized steel
$17 \leq B < 19$	6420E.27	Acciaio zincato Galvanized steel
$19 \leq B < 23$	6420E.31	Acciaio zincato Galvanized steel
$10 \leq B < 13$	6421E.21	Acciaio inox Stainless steel
$16 \leq B < 19$	6421E.27	Acciaio inox Stainless steel

* Per uso monodirezionale, utilizzare solo perno inferiore con astina singola
For monodirectional setting, use only lower pin with single rod

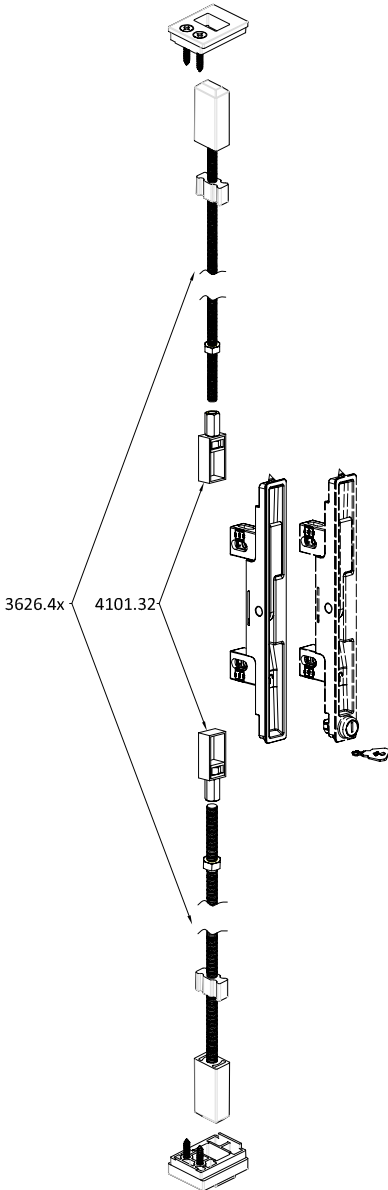
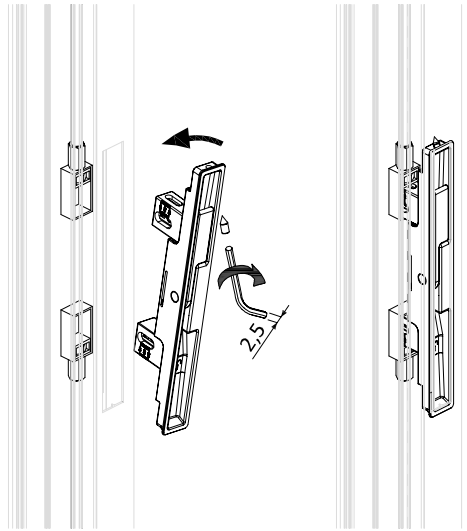
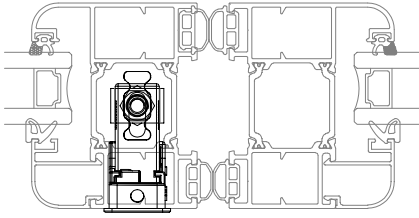
Funzionamento con aste verticali interne
Operation with internal vertical rods

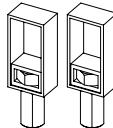

COD. MANIGLIA <i>HANDLE CODE</i>	4101.1 4101.2	4101.11 4101.12 
<p>KIT ASTE FILETTATE M8 in abbinamento con kit chiusura Topflex (interasse > 30mm)</p> <p><i>M8 THREADED RODS KIT</i> paired with Topflex closing kit (centre distance > 30mm)</p>	 <p>4101.32</p> <p>+</p>  <p>3626.42 .43 .44 .46</p> 