

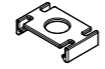

Carrelli principali

Spessore carrello	
	cava 18
	cava 22

250kg

Spessore carrello

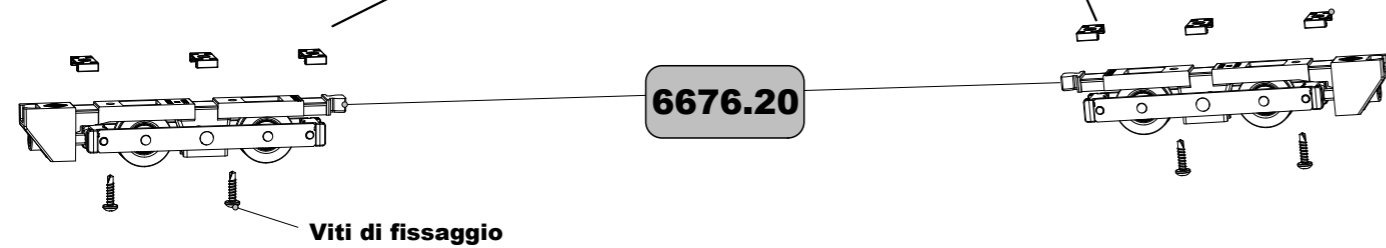

6676.20

Viti di fissaggio

Regolazione carrelli

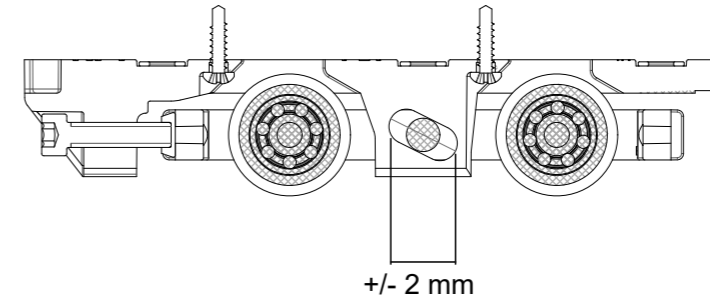

+/- 2 mm

EN - Rollers adjustment

FR - Réglage des chariot

PL - Regulacja rolek

RU -

ES - Ajuste de rueda

Carrello supplementare

6676.21

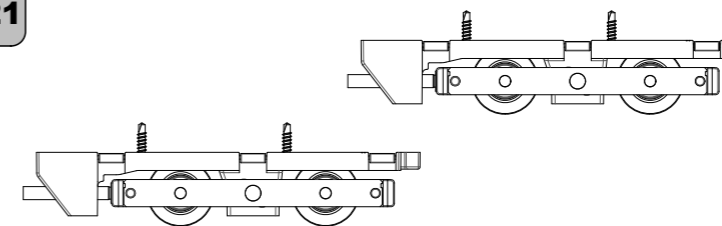

EN - Additional rollers

FR - Chariot supplémentaire

PL - Dodatkowych rolek

RU - Hááíð äîññèðòàèóññáí ðñèèèà

ES - Rueda adicional

Collegamento carrelli

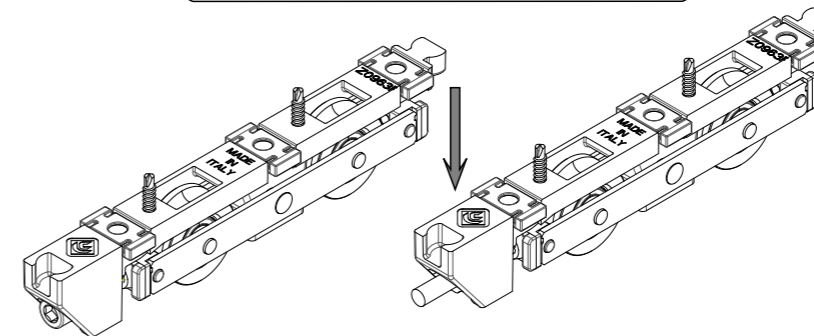

EN - Rollers connection

FR - Connexion des chariots

PL - Zwi'zek rolek

RU - Cíàäèíáíèà òàèèàèèè

ES - Conexión rueda

Carrelli Principali + Supplementari

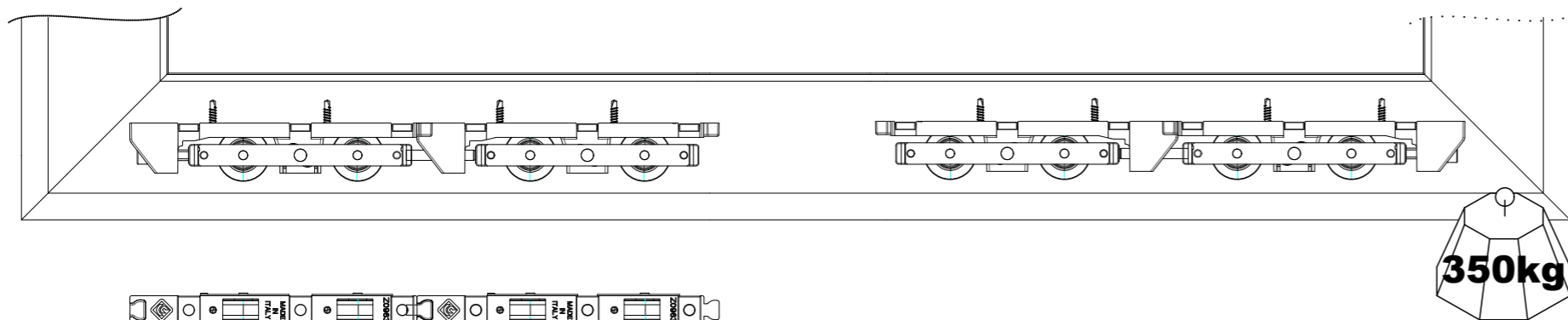

350kg

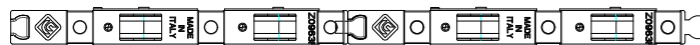

EN - Tandem rollers

FR - Chariot tandem

PL - Tandemowe rolek

RU - Òàíááííúé èàðíè

ES - Rueda tándem



REGOLAZIONE CARRELLI TANDEM

+/- 2 mm fino a 250 Kg

+250 Kg supportare l'anta

ADJUSTMENT FOR TANDEM ROLLERS

+/- 2 mm under 250 Kg

+250 Kg supportare l'anta

Applicazione

