

KARMA





KARMA

Shape your future.

ITA Il futuro si modella attraverso ripetute forme di realizzazione, nulla viene dal nulla, la sostanza energetica può essere solo trasformata in molte forme diverse.

ENG *The future is modeled through repeated embo diments, nothing comes from nothing, the energetic substance can only be transformed into many different forms.*

FRA *Le futur se forme à travers des incarnations répétées, rien ne vient de rien, la substance énergétique ne peut être transformée que sous de nombreuses formes différentes.*

ESP *El futuro se configura a sí mismo a través de encarnaciones repetidas, nada surge de la nada, la sustancia energética solo puede transformarse en muchas formas diferentes.*

PUNTI DI FORZA STRENGTHS

SCOPRI DI PIÙ
DISCOVER MORE



ITA Il design moderno ed essenziale della linea KARMA permette l'installazione su tutte le tipologie di infissi mantenendo la stessa linea estetica.

ENG *The modern and essential design of the KARMA line allows installation on all types of fixtures while maintaining the same aesthetic line.*

FRA *Le design moderne et essentiel de la ligne KARMA permet l'installation sur tous types de menuiseries, avec la conservation de la même ligne esthétique.*

ESP *El diseño moderno y esencial de la línea KARMA permite la instalación en todo tipo de luminarias manteniendo la misma línea estética.*



ITA La linea KARMA offre un'ampia gamma di soluzioni: martelline, cremonesi, maniglioni, doppie maniglie. I prodotti sono disponibili in versione minimal design, classica, con chiave, manovra logica, con manico disassato.

ENG *The KARMA line offers a wide range of solutions: window handles, cremone bolts, lift&slide handles, double handles. The products are available in different version: minimal design, classic, with key, logic operation, with offset handle.*

FRA *La ligne KARMA propose une large gamme de solutions: poignées, grandes poignées, crémones, béquilles double. Les produits sont disponibles en version minimal, classique, avec clé, manoeuvre logique, avec manche désaxé.*

ESP *La línea KARMA ofrece una amplia gama de soluciones: manillas para ventanas, cremona, tiradores, tiradores dobles. Los productos están disponibles en diseño minimalista, clásico, con llave, operación lógica, con mango desplazado.*



ITA Le versioni con chiave della linea KARMA offrono maggiore sicurezza contro i tentativi di effrazione, sono testate con coppia di rottura 50Nm

ENG *The versions with key of the KARMA line offer greater security against break-in attempts, they are tested breakup torque 50Nm*

FRA *Les versions à clé de la gamme KARMA offrent une plus grande sécurité contre les tentatives d'effraction, et sont testées à couple de rupture de 50Nm*

ESP *Las versiones con llave de la línea KARMA ofrecen mayor seguridad ante intentos de robo, están testadas torque ruptura 50Nm*



ITA Le martelline della linea KARMA sono facili da installare grazie agli stabilizzatori che sostituiscono i classici distanziali e impediscono false rotazioni della cassa

ENG *The handles of the KARMA line are easy to install thanks to the stabilizers that replace the classic spacers and prevent false rotation of the case*

FRA *Les poignées simples de la ligne KARMA sont faciles à installer grâce aux stabilisateurs qui remplacent les entretoises classiques et empêchent les fausses rotations de la caisse*

ESP *Las martelinas de la línea KARMA son fáciles de instalar gracias a los estabilizadores que sustituyen a los clásicos espaciadores y evitan la falsa rotación de la caja*

SCOPRI LA GAMMA COMPLETA DISCOVER THE COMPLETE RANGE



Martelline / Handles / Poignées / Martelinas

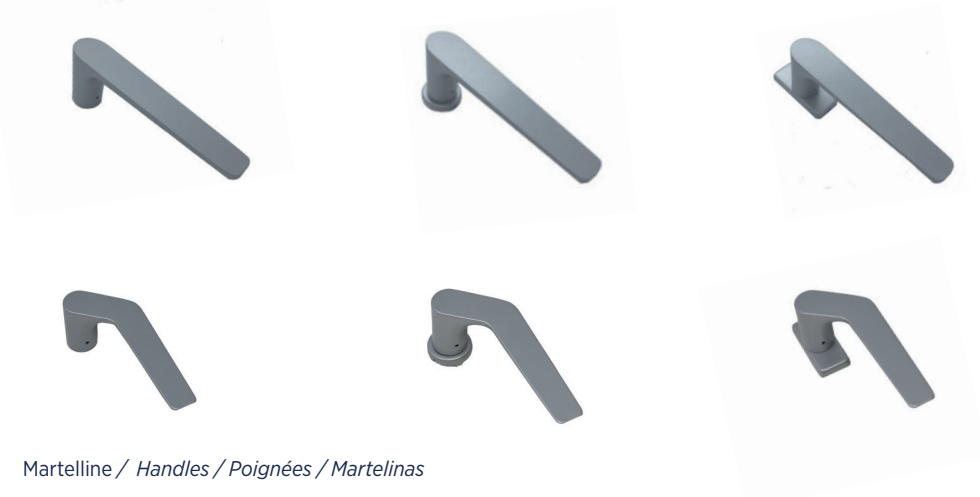

Martellina ribassata / Reduced Handle /
Poginée baissè / Maneta baja



Martellina 20° per scorrevoli | Handle 20°
for sliding | Poignée 20° pour coulissants
| Maneta 20° para correderas

Martelline / Handles / Poignées / Martelinas

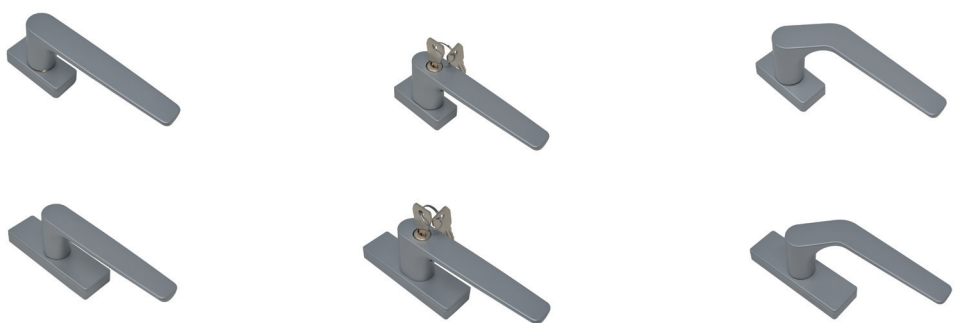

Cremonesi / Cremona Bolts / Crémones / Cremonas



Cremonese per apertura esterna
Cremona bolt for external opening
Cremona ouverture extérieur
Cremona apertura exterior

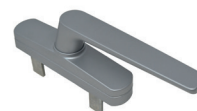

Maniglioni per alzanti / Lift&Slide Handles
Poignées pour coulissant a levage / Manillas para corredera elevable

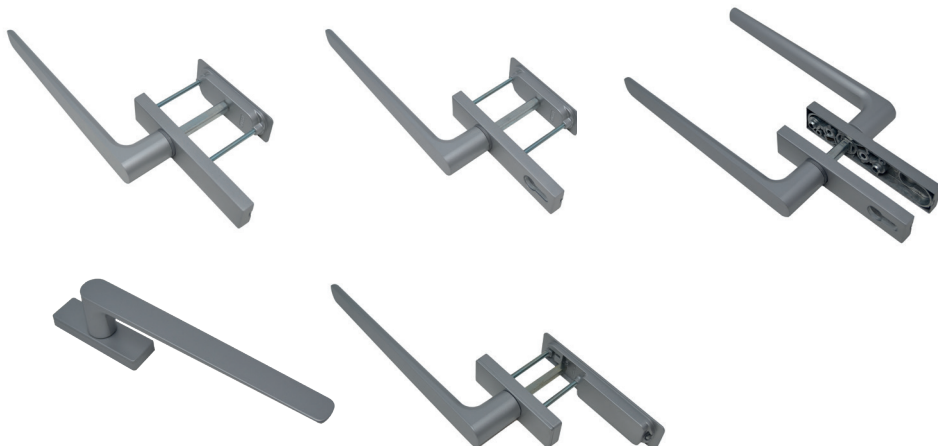

Doppie Maniglie / Double Handle
Béquilles doubles / Manillas dobles



FINITURE

FINISHES

ANODIZZATI <i>ANODIZED</i>	RAL 1	RAL 2
AXBRO (Bronzo) (Bronze)	R9010 (Bianco) (White)	R9003 (Bianco) (White)
OXARG (Argento) (Silver)	R9010OP (Bianco opaco) (Mat white)	R6005 (Verde) (Green)
OXORO (Oro lucido) (Shiny gold)	R1013 (Aavorio) (Ivory)	R6005OP (Verde Opaco) (Mat green)
OXSAT (Inox satinato) (Satin inox)	R1013OP (Aavorio opaco) (Mat ivory)	R8017 (Marrone) (Brown)
	AVOR (Aavorio scuro) (Dark ivory)	R8017OP (Marrone Opaco) (Mat brown)
	NEOPA (Nero opaco) (Mat black)	BRONZ (Bronzo effetto ossidato) (Bronze anodized effect)
	R9005 (Nero) (Black)	R9006 (Argento) (Silver)
	RAL 9016 (Bianco Ghiaccio) (Ice White)	R9007 (Grigio Alluminio) (Aluminium Grey)
	RAL 9016OP (Bianco Ghiaccio Opaco) (Mat Ice White)	MARAG (Marrone Rugoso) (Wrinkled brown)
	ARGEN (Argento effetto ossidato) (Silver anodized effect)	VSCRA (Verde Scuro Rugoso) (Dark wrinkled green)
		G6360 (Verde Gotico) (Gothic green)
		G9420 (Grigio Gotico) (Gothic grey)
		G3976 (Marrone Gotico) (Gothic brown)
		GTECHN (Grigio Tecnico) (Tech grey)
		RAL 7016OP (Grigio Antracite Opaco) (Mat anthracite grey)

FINITURA NATURALE <i>NATURAL FINISH</i>	TEK	SPECIALI (K-Finish) <i>SPECIAL FINISHES</i>
Grezzo Mill	OLDBRO (Bronzo antichizzato) (Old vintage finish bronze)	KGOLD (Oro) (Gold)
Nylon Nero Nylon Black	OLDARG (Argento antichizzato) (Old vintage finish silver)	KSATI (Inox satinato) (Satin inox)

Per tutte le informazioni sulla corretta manutenzione e conservazione dei trattamenti superficiali fare riferimento al paragrafo 5.1 delle LINEE GUIDA SU GARANZIA PRODOTTI E RESPONSABILITÀ.

For all information on the correct maintenance and conservation of surface treatments, refer to paragraph 5.1 of the GUIDE LINES ON PRODUCT GUARANTEES AND RESPONSIBILITIES



Master Italy S.r.l
S.P. 37 Conversano - Castiglione km 0.570 - Conversano (Ba) Italy
Customer Service +39 080.4959823 | Fax. +39 080.4959030
info@masteritaly.com



masteritaly.com



Master Italy



Master Italy



Master Italy